

# Society helps handicapped reach potential

By FRANK LEIGH-SPENCER

There are 31 special people on Salt Spring. They are special because they are a small minority. They are the mentally handicapped people who are helped on a daily basis by the staff of the achievement centre, one of the major programs of the Salt Spring Community Society.

Under the leadership of Louise Ducet, 10 full-time and part-time employees, as well as a corps of dedicated volunteers, spend many, many hours on a one-to-one basis helping the handicapped to live more meaningful lives within their individual capacities.

"They are a dedicated staff who, in addition to their daily work hours, give much of their spare time to their tasks," said Ducet. "And without the tremendous effort of the volunteers we wouldn't be much more than a baby-sitting agency."

One of the facets of the work of the achievement centre is the tutoring program conducted by six volunteers. At the moment they have seven students, some of whom are learning to read and others are being taught how to count money. Learning about personal hygiene is also part of the tutoring.

"It is educational, with a practical application to help improve individual lifestyles," Doucet explained. "As an example, when teaching about the value of money and counting it, the student is given a specific budget figure for an imaginary shopping trip. Then, assisted by using food store advertisements, (he or she) selects the items required, determines the cost and at the same time stays within the budget figure. It takes a lot of time and a lot of patience but the reward is in the light of delight and understanding of the expression of the student."

When individuals first come to the centre, a program is worked out for them in consultation with their parents, relatives or guardians, and they are integrated into the overall operation of the centre in the program which is best suited to them. The programs run from 10 am to 3 pm five days a week, and transportation is provided to and from their homes, if required.

Four years ago the Achievement Centre introduced an eight-month training program for people interested in working with the mentally handicapped. The course is limited to three participants. To date nine people have graduated from the course and all have found employment — most of them with the local achievement centre.

One of the graduates of the training program is Don McEacher who supervises the woodworking shop at the Community Society's home for handicapped on McGoldrick Place. Each day, he spends five or more hours helping and guiding an enthusiastic — if small — group of handicapped people in the basics of woodworking with both hand and power tools.

As in all the projects of the centre the objective is to give the individual a sense of accomplishment, and of being part of a meaningful program.

Many of the articles produced in the workshop — such as hanging seats for children, puppets and walking canes — are sold through the centre's Clothing and Craft Store which opened last spring in Ganges.

"It is a moment of intense pride for the individual when his work is

CALL TODAY  
656-1125

## SLEGG LUMBER

A COMPLETE HARDWARE AND BUILDING CENTRE



MON-SAT  
7:30-5:30  
SUNDAY  
9:30-4:30

FREE COFFEE AND DONUTS  
ENTER TO WIN PRIZES  
IN STORE SPECIALS

### DEMO-DAY MADNESS

★ IN STORE DEMONSTRATIONS SATURDAY OCT. 15 ★

• MAKITA Power Tools • REDI-FLOr Oak Flooring • MEDIEVAL Architectural Glass • VARATHANE Coatings • OSBURN Wood Stoves • BOSTITCH Air Nailers

SALE STARTS SATURDAY

SALE PRICES IN EFFECT UNTIL OCT. 22 OR WHILE STOCK LASTS. SHOP EARLY FOR BEST SELECTION.

#### REDI-FLOr SOLID OAK FLOORING

PARQUET SQUARES AND OAK PLANK

-Prefinished with polyurethane for a durable no-wax finish.  
-Tongue and groove for an easy do-it-yourself installation.

INSTALL REDI-FLOr TODAY, ENJOY IT FOR A LIFETIME.



REDI-FLOr PARQUET  
Natural - Chestnut - Walnut

SALE 2.99 SQ.FT.

SUPER PLANK  
Natural - Honey Brown

SALE 4.89 SQ.FT.

SUPER PARQUET  
-Honey Brown Stain Finish -Square Edge

SALE 1.99 SQ.FT.

#### ATTENTION CONTRACTORS

BOSTITCH® AIR TOOL DEMO!

WITH RICK VENNE

TRY ONE FOR YOURSELF — SPIKERS, STAPLERS, ROOFING AND FINISHING GUNS.

SAVE TIME AND MONEY!

BRAD NAILER #T-29.....288<sup>00</sup>  
SPEEDAIRE 2 H.P. COMPRESSOR.....588<sup>00</sup>  
BOSTITCH 3" SPIKES.....CTN 25<sup>00</sup>  
SPIKERS #N80S.....569<sup>00</sup>  
COIL NAILERS #N80C.....569<sup>00</sup>  
SHEATHING STAPLER #T36-50.....479<sup>00</sup>



CONSTRUCTION FASTENING CENTER

WE STOCK A COMPLETE RANGE OF AIR NAILERS, HOSES, FITTINGS, AND ACCESSORIES



PROFESSIONAL CLEAR FINISH

1L 10<sup>99</sup>  
4L 30<sup>99</sup>

A ONE DAY PROFESSIONAL FINISH

SPECIAL PURCHASE! STOCK UP NOW AND SAVE



DANISH OIL FINISH

1L 9<sup>79</sup>  
4L 27<sup>99</sup>

#### ARCHITECTURAL GLASS DOOR INSERTS

LEAD ... BRASS ... BEVELLED ... SANDCARVED ... THERE'S A WHOLE WORLD OF ORNAMENTAL GLASS PRODUCTS ... AND MEDIEVAL HAS THEM ALL!

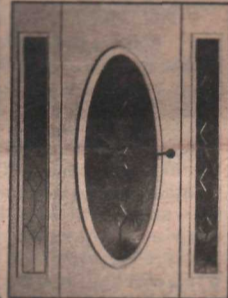

EASY TO INSTALL IN MOST NEW and EXISTING DOORS

Drop in on Saturday and we'll show you how!

SALE PRICED 30% OFF

#### 5TH ANNUAL DEMO-DAY SALE

#### Makita Power Tools

PALM SANDER SALE 69<sup>95</sup>  
7 1/4" CIRCULAR SAW SALE 159<sup>95</sup>  
1/2" REVERSIBLE DRILL SALE 139<sup>95</sup>  
12" PLANER-JOINTER SALE 1659<sup>00</sup>

ALL STOCK TOOLS NOW ON SALE AT OUR LOWEST PRICES OF THE YEAR.



#### WOODSTOVES AND FIREPLACE INSERTS

See for yourself why Victoria's own, Osburn Woodstoves, have become a winner around the world. BURNING MODELS ON DISPLAY



SAVE HEAT! SAVE UP TO 154<sup>00</sup>  
EXAMPLE: REGENT 1000 REG. 749<sup>00</sup> SALE 595<sup>00</sup>



MODEL 2500 GARAGE DOOR OPENER CONVENIENT AND SAFE 1/3 H.P. MOTOR 179<sup>00</sup>

ROUTER BITS BY VERMONT AMERICAN 40% OFF  
40 TOOTH CARBIDE TIP SAW BLADE 9<sup>95</sup> EA.

PAINT THINNER 4 litre SALE 2<sup>99</sup> EA.

QUALITY AXES AND SPLITTING MAULS  
2 1/2 LB. AXE.....9.95  
3 1/2 LB. AXE.....12.95  
6 LB. MAUL.....12.95  
8 LB. MAUL.....14.95

TONGUE AND GROOVE CLEAR CEDAR PANNELLING NOW ONLY 12<sup>95</sup> 14 SQ.FT. BUNDLE

Armstrong CANDIDE LINO 15<sup>99</sup> SQ. YD.  
Sale Price applies to stock only, approximately 20 rolls assorted patterns, colours.

#### LUMBER SPECIALS

2"x4"x8' UTIL.....99¢ EA.  
2"x6"x92 1/4" HEM STUDS.....1.69 EA.  
1"x8"x8' RESAWN.....89¢ EA.  
2"x6"x10' UTIL. FIR.....2.15 EA.  
2"x6"x12' UTIL. FIR.....2.89 EA.  
2"x8"x8' UTIL. HEM.....2.29 EA.

#### PLYWOOD BARGAINS

1/4" GOOD 1 SIDE ONLY.....11<sup>95</sup>  
1/4" O.S.B. SHEATHING ONLY.....5<sup>19</sup>  
1/4" PEG BOARD ONLY.....12<sup>49</sup>  
1/2" GOOD 1 SIDE ONLY.....16<sup>95</sup>  
3/8" O.S.B. SHEATHING ONLY.....6<sup>19</sup>  
11/16" CREZONE 2"x8' ONLY.....9<sup>95</sup>  
3/4" GOOD 1 SIDE ONLY.....22<sup>95</sup>  
7/16" O.S.B. SHEATHING ONLY.....7<sup>19</sup>  
11/16" CREZONE 2"x8' ONLY.....9<sup>95</sup>

ONLY OAK PLYWOOD Special Purchase!! 38<sup>88</sup>  
3/4" OAK PLY, 4'x8'.....38<sup>88</sup>

#### DOORS — DOORS — DOORS

MAHOGANY PREHUNG DOOR UNITS.....ONLY 36<sup>88</sup>  
HERITAGE PREHUNG DOOR UNITS.....ONLY 68<sup>88</sup>  
EXTERIOR PREHUNG STEEL DOORS WITH SILL, WEATHERSTRIP, & TRIM.....ONLY 178<sup>00</sup>  
GLASS — ADD ANY DECORATIVE GLASS TO THESE EXTERIOR DOOR THIS WEEK AT..... 30% OFF

#### PINE BIFOLDS

LOUVRED 1/2 LOUVRED  
2-0 — \$58.88 2-0 — \$64.88  
2-6 — \$62.88 2-6 — \$68.88  
3-0 — \$68.88 3-0 — \$76.88

#### HERITAGE BIFOLDS

2-0 — \$49.88 4-0 — \$99.88  
2-6 — \$54.88 5-0 — \$109.88  
3-0 — \$59.88 6-0 — \$119.88



#### SAVE NOW ON ALUMINUM GUTTER AND DOWNPIPES

-Brown or white baked enamel finish  
-Easy to install  
-Lasts for years

10" GUTTER.....6<sup>99</sup>  
16" GUTTER.....10<sup>99</sup>  
2"x3" DOWNPIPE 10'.....7<sup>19</sup>  
2" ROUND DOWNPIPE 10'.....5<sup>79</sup>  
Aluminum gutter never rusts, rots or corrodes

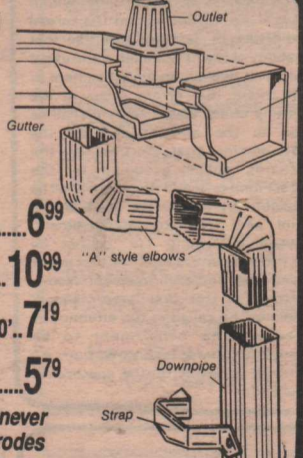

#### INSULATE NOW!!



Insulate now with quality Fibreglass insulation and save on heating costs.

R12-15" 50 sq.ft.....\$11.88  
R12-15" 100 sq.ft.....\$22.88  
R20-15" 25 sq.ft.....\$9.88  
R20-15" 55 sq.ft.....\$20.88

#### GYPROC SALE

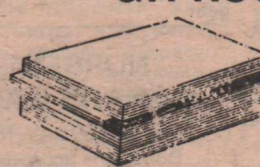

1/2"x4'x8' SHEET NOW ONLY 5<sup>39</sup> EA.

#### ROOFING SPECIAL

Eso No 1 T-Lock shingles, full warranty, the genuine article, not an inferior brand.

10 YEAR T-LOCK SHINGLES covers 32 sq.ft. 11<sup>88</sup> per bundle

15 YEAR T-LOCK SHINGLES covers 32 sq.ft. 13<sup>88</sup> per bundle



#### ★ INSTALLED ROOFING ★

Call for a free estimate  
All work fully guaranteed — on special this week  
Professional installations done by "Sam the Roofer"



CONCRETE MIX JUST ADD WATER 2<sup>99</sup> 25 KG ONLY

KILN DRIED CLEAR HEMLOCK 1"x6".....ONLY 69¢ FT.  
Excellent stock — great for all finishing projects 1"x8".....ONLY 99¢ FT.

4" FLUORESCENT FIXTURE Easy to install, 2 light fixture with wrap around acrylic shade. SUPER BUY 24<sup>95</sup> BULBS EXTRA

GENERAL PURPOSE CEMENT MIXER SALE PRICED AT 299<sup>95</sup> 8 only at this price  
1/3 H.P. electric motor, 3 cu.ft. capacity, fixed wheels

# DRIFTWOOD CLASSIFIEDS

## CLASSIFIED RATES:

LINERS: \$4.25 minimum, 25 words or less; 17¢ each additional word.  
 CLASSIFIED DISPLAY: \$7.60 per column inch.  
 OFFICE HOURS: Monday to Friday, 8:30 am. - 4:30 pm.  
 CLOSED: Saturday & Sunday.

## DEADLINES:

LINERS & CLASSIFIED DISPLAY: 3 pm. Monday  
 TOO LATE TO CLASSIFY: Noon Tuesday

All classifieds must be paid in advance. Bring your ad into our office at 126 Upper Ganges Rd. or mail with cheque or money order to Box 250, Ganges, B.C. V0S 1E0  
 OR USE YOUR:

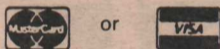

number to place CLASSIFIED ADVERTISING BY PHONE. Simply call us & give us your CHARGE CARD NUMBER and its EXPIRY DATE.  
 CALL 537-9933

## NOTICE OF COPYRIGHT

Full, complete and sole copyright in any advertising produced by Driftwood Publishing Ltd. is vested in and belongs to Driftwood Publishing Ltd. No copyright material may be reproduced in any form without the prior written consent of Driftwood Publishing Ltd.

## AGREEMENT

All claims of errors to advertisements must be received by the publisher within 30 days of the first publication. It is agreed by any display or classified advertiser that the liability of the newspaper in the event of failure to publish an advertisement or in the event that errors occur in the publishing of any advertisement shall be limited to the amount paid by the advertiser for that portion of the advertising space occupied by the incorrect item only and that there shall be no liability in any event beyond the amount paid for such advertisement. Driftwood Publishing Ltd. cannot be responsible for errors after the first day of publication of any advertisement. Notice of errors in the first week should immediately be called to the attention of the advertising department to be corrected for the following edition. All advertising is subject to the approval of the publisher.



## Annual Subscription Rates:

IN THE GULF ISLANDS \$12  
 Elsewhere in Canada \$18  
 Foreign \$60

## PROVINCE-WIDE CLASSIFIED

BLANKET CLASSIFIEDS:  
 25 word ad - \$159  
 (less than \$2 per newspaper)  
 Call for information:  
 537-9933

## For Sale

### KINDLING

Large box, approx. 30 lb., of hand split cedar.  
 \$5 PER BOX DELIVERED  
 537-2801 (evenings)  
 39-1, 41-1

Beautiful contemporary matching oak pieces: two square end tables, \$105 each, one low square chest, nautical brass drawer pulls, \$300. 537-5188. 1

Exercise equipment, York 2001 home gym, \$175. Rowing machine, \$125. 537-4358. 1

### GIPPO FIREWOOD

GUARANTEED CORD CUT, SPLIT & DELIVERED  
 Fir - \$80. Alder - \$80  
 AOS, 1/2 cord rates  
 537-5380, eves.  
 30-tfn

Girl's bed, white, bookcase headboard, three drawers. Good condition. \$125. 537-2157, after 5 pm. 1

Kelvinator fridge, frost free, yellow, \$250. Dishwasher, portable, brown wood top, \$195. Dining room suite, solid maple, round extension table, 5 captain's chairs & buffet, \$850. All in good condition. 537-9451. 1

### 10 Years of the Best!

### RICE BOWLS

BY LARI ROBSON  
 OCT. 4 - 18 at the GULF JEWELS GALLERY  
 HOURS: 11 - 4:30 pm.  
 Tuesday - Saturday  
 112 Hereford Ave.  
 Phone 537-5260  
 40-2

Win a Royal Viking Cruise for 2 Hong Kong to Honolulu, Dec. 4 - 20. Tickets \$2 ea. or 6 for \$10 available at Community Centre and et cetera. 38-6

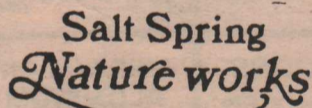

### SUSHI

traditional Japanese finger food  
 Featuring the sharp knives and attention to detail of Joe Clark (Jo San).  
 FRIDAY & SATURDAY  
 October 14 - 15th  
 537-2325

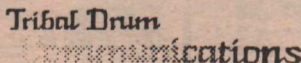

### COMPUTERS

APCO XT and AT fully IBM compatible systems. MAXAR 386 high performance computers. NEC, SAMSUNG, DATATRIN displays. STAR and NEC printers. SEAGATE and CMS hard disk drives for IBC and MACINTOSH systems. Point of sale systems. We can supply almost any computer peripheral at competitive prices with software and technical support on-island. Fully equipped professional service facility. Laser printing and desktop publishing from IBM and MACINTOSH disks. Computer graphics service. We provide training and support for any system that we sell. Call 653-4563 for free consultation. 1750 Fulford-Ganges Road. 1

## For Sale

### TOPSOIL

BEAUTIFULLY SCREENED FOR LAWN OR GARDEN  
 7-yard loads maximum  
 Gravel Supplies: 4-yard max.  
 748-7866

New diving equipment includes wet suits, 180 lbs., 6' male: 135 lbs., 5' 4" female, best sharkskin neoprene, weight belts, face masks, snorkle, heavy duty fins, carry bag. Never used, \$350 each set, or best offer. Deep freeze, near new, 12.2 cu. ft., \$275. New Moffat dishwasher, \$425. Beehives, rotovator, tillmatic and Lowrey organ & seat. 653-4304 or weekends, 537-4492. 1

2 recliner chairs, \$50 or \$75. Mirrored medicine cabinet, \$25. Johnnie cabinet, \$15. Swag lamp, \$20. 537-2316. 1

### INSTANT CATERING

Entrees, rice or potato dishes, vegetables, salads, desserts, baked goods, mayonnaise, dressings, dips, jams, jellies & more.  
 TIME SAVERS — AND GOOD FOOD TOO!  
 Now available at:

Alisi Catering  
 UPPER GANGES CENTRE  
 537-2578  
 34-tfn

Is your WELL WATER safe to drink? Contamination can occur without changes in colour or taste.

BE SAFE — HAVE YOUR WATER TESTED



10124 McDonald Pk., Sidney  
 MB RESEARCH 656-1334  
 31-tfn

Who is moving next to the Library on McPhillips Ave. on November 1st. Village Electronics, 537-4544. 1

Fall sale Mouat's Top Floor. Ladies, mens and childrens wear. 1

### MOBILE MARKET

(Across from School Bd. Office)  
 NOW AVAILABLE:  
 HAAGEN DAZS  
 ice cream & Island fruitsicles  
 OPEN TUESDAY-SATURDAY  
 1

Large shipment of coffee tables, lamp tables and desks, just arrived Vancouver Furniture Show. Newest and latest models at very low prices. Good selection of pre-owned tables on sale now. Also, large purchase just made on used office desks and room dividers. Our Fall Sale is now! Save on thousands of pre-owned and as new items and new at BUY & SAVE, 9818 - 4th St., Sidney, B.C.

### A Thousand Words Picture Framing

Custom framing of original artwork, prints, posters, needlework, conservation framing, dry mounting, shrink wrapping, photocopying, object framing, creative matting, etc.  
 537-5131  
 785 Fulford-Ganges Rd.  
 31-tfn

## For Sale

### CHEAP SHOP, BARN OR MEZZANINE?

50 heavy duty trusses, 23' long. 80 L.F. of 6" x 10" steel beams. 6 steel posts, 4" x 4" x 10'. Will cover 2250 sq. ft. Asking \$2500.

383-4233 weekdays

70 large split cedar fence posts, \$2.50 ea. 537-9510. 1

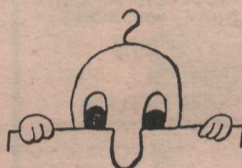

### OUTDOOR TOY SALE

Table lamps \$20.95  
 Morning Star "Incense"  
 Changes Make-up  
 100% cotton & 50/50 Big Ts  
 Sue Bradford's dried flowers  
 Halloween stuff

### The General Store

GANGES, B.C.

2 platform rockers, \$10 ea.  
 Swivel chair, \$10. Girl's size 11 ballet slippers, \$6. Garnet column speakers, \$250 pr.  
 New hardshell electric guitar-case \$55. Roland Space-Echo, \$200. Phone 653-4563. 1

### PLEDGES TO TERRY FOX RUN

NEED TO BE INTO THE BANK BY OCTOBER 21st. NEW PLEDGES ARE WELCOME!  
 THANK YOU, SALT SPRING!  
 41-2

Shower cabinet, 30" x 30" steel complete with head, new taps, curtain, some rust. Free for the taking. 537-9529. 1

### LUMBER

CEDAR: Siding-wain edge or common; beams; slabs

### Mel's Mill

397 Musgrave Rd., Fulford  
 653-4272  
 20-tfn

Rabbit meat for sale. And eggs. Fryer rabbits, \$2.50/lb. Free recipes with rabbit. Rabbit manure, \$3 bagged, dry. 240 Musgrave Rd. 653-9585. 38-4

### WOOD STOVES

\* SEEFIRE \* BIS & MANUFACTURED FIREPLACES \* COMPLETE METAL CHIMNEYS & ACCESSORIES.  
 For Sales & Installations, call:  
 HOGAN CHIMNEY SWEEPS  
 537-5340  
 40-tfn

Dining room set, \$400. Chesterfield and chair, \$300. Trundle beds, \$50. Braided rug, \$25. Bed spread, as new, \$25. Table & chairs, \$45. Plastic pool, as new, \$18. Fridge, working, free. 537-2612. 1

### DON'T MISS THE MASKS at the Market

SATURDAY MORNINGS  
 OCT. 8 till HALLOWEEN  
 1

## For Sale

Ships Anchor pizza (formerly DJs Pizza) located at the Ships Anchor Restaurant. Watch for our menu in next week's paper. 537-5338. 1

A.C. Generator, 2400 watts with 8 hp. engine, centrifugal clutch mounted on platform with wheels. 653-9298. 1

Hay, \$1.50/bale. 50 bales. Call collect, Vancouver, 732-6738. 1

### KONIG & SON FIREWOOD

Serving Salt Spring Seven Years  
 COMPETITIVE & RELIABLE SEASONED  
 537-9531  
 40-tfn

Salt Spring Island lamb. Also, custom meat cutting, double wrapping & quick freezing. Pat's Custom meat. 653-4352. 20-tfn

### Fall & Winter Sale in the Pro Shop

SALT SPRING ISLAND GOLF CLUB

### 25% OFF

ALL MERCHANDISE (except golf balls)  
 Sale starts Saturday, Oct. 15th  
 Open 7 days a week 8 - 6 pm.  
 41-2

McClary wood cookstove, \$75. Bamboo bookcase, \$30. Singer treadle sewing machine, \$50. Oak sideboard, \$25. Birdseye maple bunkbeds, \$125. Antique curved-front dresser, \$150. Phillips hot-air popcorn popper, \$15. High-density foam mattress, \$50. Tree planting bags, \$35. Cork boots, size 11, rubbers and leathers, \$25. 653-9460 or 653-4537. 1

### FIREWOOD

Get your wood now so it is seasoned by fall!  
 Logging truck loads of alder, maple mix. \$500 delivered. 10 cords minimum.  
 537-4274 days, 537-9667 eves.  
 35-tfn

### Fresh Prawns & Crab

SATURDAY MORNINGS  
 GOVERNMENT DOCK, Ganges  
 Follow the signs  
 20-tfn

### TOP SOIL

ALSO:  
 CLEAN FILL  
 653-4520  
 20-tfn

### Garage Sales

Moving - 9-4 pm. Saturday, Oct. 15th, 575 Lower Ganges Rd. 653-4304 or 537-4492. Various tools, extension ladders, wheelbarrow, furniture, household articles and diving gear. 1

### NURSES' GARAGE SALE

COMING SATURDAY, NOV. 26  
 Donations accepted.  
 Call 653-4293 for further information.  
 40-4

## Cars, Trucks

1980 Mercury Zephyr "Ghia", 4 door sedan, 6 cyl., ps., pb. Clean, low mileage. \$3250. Phone 537-5649 after 6 pm. 1

1970 Ford Cortina MK II, runs, \$150. 653-9256. 1

1980 Chev Van, small V8, auto, ps., pb., cruise, insulated, carpeted, bed, table, benches, captain's chairs, seats six, windows, skylight. New: brakes, shocks, battery. \$3800. 653-9473. 1

1976 Dodge Van, ps., pb., short body. Overdrive transmission, runs well. Reliable. \$1400. 653-9460 or 653-4537. 1

1973 Chev Bel Air, rebuilt engine, good for parts. \$225. Phone 537-5263 or 537-5837. 1

1981 Mustang 2-dr. coupe, 4 cyl., 4 spd., low mileage, clean inside and out. Reliable, economical transportation. Offers on \$2995, trades considered. 653-9258. 35-tfn

1973 Dodge Dart, 318 V8, auto, ps., pb., reliable, \$800. 1974 F250 4 x 4, 3/4 ton, good shape, \$3000. Phone 537-4274 and leave message for viewing. 38-tfn

### Mobiles, Trailers

13 ft. 'Trillium' travel trailer, 3-way fridge, stove, sleeps 4. \$1500. 537-2029. 40-2

Triangle R. V. Centre offers excellent highway exposure for your consignment vehicle. Also, parts, service, propane, sani-station, and 24-hour car & R.V. Wash. Your complete R.V. Centre. Triangle Home, Ltd., Sidney. Your first R.V. Centre off the ferry. 656-1122. DL5916. 37-tfn

### Boats

For sale, 36' sloop, diesel engine, \$15,000. 656-9858, 41-2

18' Silverline fibreglass runabout with 115 hp. Evinrude, and 7.5 hp. kicker, full instrumentation, depth sounder, rod holders, full canvas, teak trim, carpets, Calkins trailer. Excellent quality boat. Great for fishing or skiing. Cruises at 40 mph. \$5900. Galiano, (604) 539-2010. 1

17 ft. Sangster with 90 hp. Johnson O/B & trailer, good condition. \$4,400 obo. Will consider trade for loader or backhoe. 537-5788. 1

26 ft. Thunderbird, very good condition, cosmetic work only needed. 10 hp. Honda, VHF, depth sounder, 4 sails, \$4900. Phone 1-224-3119, Vancouver. 40-3

Dean Sevoid, Shipwright, 15 yrs. experience, refits, maintenance, repairs, renovations. Please phone 653-9483. 20-tfn

Santana 20, high performance racing sloop, good cruiser, 4 sails, great shape, \$4900 firm. 539-2719, Mayne Is. 40-3

### Livestock

A HORSE IS ONLY AS GOOD AS HIS FEET!  
 FARRIER with 20 years experience is now residing on Salt Spring. Shoeing, trimming and corrective work.  
 ROB SCHERES - 537-4193  
 40-4

2 pigmy goat does, 10 mos. and 6 mos. Grey. \$150 ea. Phone 1-749-6320, Lake Cowichan. 41-3

**Livestock**

**Restoration of Equestrian facility**

ALL PERSONS INTERESTED PLEASE ATTEND A MEETING Thursday, Oct. 27 — 8 pm. at Farmers' Institute Bldg. Rainbow Rd.

**Found**

Pair glasses on Bradley and Woodland Drive. Claim at Driftwood.

Man's watch on Stark Rd. Please identify and claim at Driftwood.

Ring, at Dagwoods. Can be identified at Driftwood.

Keys, Tuesday afternoon, Oct. 4th, at the CRD parking lot. Claim at Driftwood.

Aran type sweater at Portlock Park. Phone 537-2935.

**FOUND SOMETHING?**

Give us a call because ads in this classification are

**FREE!**  
Gulf Islands  
Driftwood  
537-9933

**Births**

Don & Zella Madsen are pleased to announce the arrival of a grandson, Alexander, 7 lbs. 7 ozs., Sept. 30th, 1988. Proud parents Paul and Kim Madsen (nee Lenour) of Vancouver.

Pre-Natal Information series; pre-and post-natal exercise classes, baby talk lunch break - Thursdays. Heather Martin. Licensed Midwife. 537-9729.

**Announcements**

We're moving Nov. 1st to McPhillips Ave., next to the Library. Village Electronics, 537-4544.

Now serving Pizza - Ships Anchor Pizza (formerly DJs Pizza). Watch for our menu in next week's paper. 537-5338.

**Continuing Education**

STILL NOT TOO LATE! 2 seats left for 'Son of Heaven' 2 nights left in the Plant Kingdom

Painting in Oils - Oct. 17 Industrial First Aid - Oct. 25 Halloween Make-up - Oct. 26 Women's Self-defense - Oct. 30

South Africa Film Series starts Oct. 26th

Computer Lab - Thurs., GISS, 5 - 7 pm.

Tutoring? G.E.D.? Reading?

Give C.E. a call - 537-2822 Mon. - Thurs., 10:30-2:30pm. Drop by our office in lower Mouat's Mall.

**Personals**

Watch for us on November 1st. We're opening on McPhillips Ave., next to the Library. Village Electronics, 537-4544.

Would the person who stole Jean Knight's violin shaped sign from 190 Mobrae, please return it. No questions asked. Jean does so much for this community (Save the Childrens Fund, Foster Children overseas, Hospital volunteer work, etc.) This sign was a gift to her for her kindness to other people. She would like it back. Thank you, Jim McMahon, 537-9271.

**Personals**

C.A.C. needs volunteers - see Arts Page.

**Have you Paid Your Pledge? TERRY FOX RUN**  
MONIES DUE OCT. 21st



OUR SELECTION INCLUDES:  
● Walking Aids ● Wheelchairs ● Aids for daily living ● Diabetic Products ● Diagnostic Aids ● First Aid ● Incontinent Supplies ● Support Stockings ● Ostomy ● Patient Aids ● Sports Medicine ● Surgical Supplies ● Supports and Braces ● ... and much, more ...

We offer a variety of Home Health Care products for rental - a great way to try a product prior to making a purchase.



**PHARMASAVE**

GANGES NO. 120

9 - 6 pm. Mon. - Sat.

537-5534

Getting married? Join "Sharon's" Bridal Registry. For your personal appointment, call 537-4014.

**In Memoriam**

**B.C. Heart Foundation**

1008 Blanshard St., Victoria, B.C. - V8W 2H2

736-4404

A donation in the name of someone you loved or knew is but a phone call/letter away and we'll acknowledge your caring gift with a card to the family.

**Travel**

**Hanna Air Services**

Charter Sea Plane, Ganges to Vancouver - \$115  
Call toll free pager: 1-979-1906 or collect to office: 245-8333, 24 hrs.

**Wanted**

Wanting to rent commercially zoned property for boat storage. 1 - 2 acres preferred. 537-4202.

Landscaper and gardener horticulturally trained and experienced in design, planting, maintenance, pruning and greenhousing. Fully insured. Phone David, 653-4270.

We buy furniture, antiques, collectibles, odds 'n' ends, tools, strange and wonderful curiosities, and much, much more. The Great Ganges Junk Co., 537-4421.

**Work Wanted**

Handyman, experienced carpenter or helper. Exterior, interior renovations, painting, plumbing and roofing. General home maintenance and repairs. Large and small appliance repairs. Property maintenance and caretaking. Also, experienced automotive mechanic and chainsaw repairs. Reasonable rates. John, 537-5177.

**Work Wanted**

Available immediately for general yardwork, house-keeping, cleaning and organizing. 653-9576.

Early bird housecleaning services, very reliable. Morning household help, cleaning, ironing, cooking, etc. \$8/hr. Phone 537-4183.



CALL:

**Dirty Old Maids**  
for all your cleaning needs  
653-4580 or 537-9567

**Help Wanted**

Mature, responsible N/S woman, who loves children, for occasional overnight baby-sitting of small child. 537-4358.

General carpentry, fencing and handyman services, required by small farm on on-going part-time basis, flexible hours. Burgoyne area. 653-4364, after 6 pm.

C.A.C. needs volunteers - see Arts page.

Shop person, full time, experience not necessarily needed. Apply Anvil Iron Works, 111 Robinson Rd.

Cash in on the fall and Christmas selling season. Distribute nationally-known products. Phone for appointment. 537-2446.

**Wanted to Rent**

**HOME OWNERS**

WANT TO RENT YOUR HOUSE but are worried about the problems that go with renting? LET ME HANDLE THIS FOR YOU!

R.D. Property Management  
537-5411

**Salt Spring Property Management**

\* RESIDENTIAL RENTALS \*  
\* PROPERTY WATCH \*  
The Economical and Reliable Choice  
PETER JACQUEST  
Box 1012, Ganges  
537-5650

W/F or seaview home to house sit by reliable resident and property owner. If you are going south this winter and want your home sat, call Santy G. Fuoco, 537-5577 office or 537-2773 residence.

Single N/S working woman requires small house or cottage near Fulford School. Lillian - 653-4513.

**For Rent**

Lease space downtown area—commercial space for rent in downtown core—2000 sq. ft., high traffic area. Call Arvid at 537-5568.

Large studio c/w 1 bdrm. living quarters, north end, long term, \$600/mo. Peter 537-5650 after 6 pm. Salt Spring Property Management.

\* GANGES HARBOUR VIEW \*  
GANGES APARTMENTS  
Crofton Road  
Bachelor, 1 or 2 bdrm. suites. Seniors - no children or pets. Contact A.P. Lloyd - 537-2670

**For Rent**

3 bdrm. home near village, furnished, \$450/mo., Nov. 1/88 - April 1/89. Utilities included in rent. Call Santy G. Fuoco, office, 537-5577 or eves. 537-2773.

Columbine Cottage Bed & Breakfast: Winter Weekend Rates: 3 days/2 nights, \$100/couple. 653-4561.

1 bdrm. cottage for rent starting Nov. 1st on St. Mary Lake. Call 537-2956.

New 2 bdrm. cottage available Nov. 1st. Close to town, long term, \$480/mo. Phone Peter, 537-5650, after 6 pm.

Rent Meaden Hall in the Legion for anniversary, weddings, birthdays or just plain fun parties. Book early. Call Jim Andrews, 537-5822, for information.

**STORE FOR LEASE**

Approx. 850 sq. ft. 107 McPhillips Ave. (Presently Directions Clothing Store)  
1-683-5144, Vancouver mornings or evenings or contact KIS Office Services, 107 McPhillips Ave.

3 bdrm. waterfront, quiet area, close to Ganges. 4 appliances, electric heat. \$750/mo. 6 month let Nov./May. References essential. Write to Dept. R, c/o Driftwood, Box 250, Ganges, B. C. V0S 1E0.

**Community Services**

Cancer support group held once a month in private homes. Confidentiality ensured. Please call 537-2768.

Are you having a problem controlling your eating? If you're interested in helping yourself, we're interested in helping you. Call Overeater's Anonymous, 537-9253 or 537-2618.

Dressings are free to Cancer patients by the Order of the Eastern Star. Contact Carol Miller, 537-4023 or Health Services, 537-5541.

Alanon afternoon/evening meetings. Call 537-2317, 653-4288.

A.A. MEETINGS, Salt Spring Island, phone 537-9337 or 537-2317. GALIANO - 539-2235 or 539-5770. PENDER - 629-3312.

**Notices**

ISLAND STREAM AND SALMON ENHANCEMENT SOCIETY

**Work Bee**

Mouth of Cusheon Creek Sunday, Oct. 16th — 11 am. Meet at new hatchery, corner of Cusheon Lake Rd. and Stewart Rd. Bring lunch, gumboots and bucket. Everyone Welcome. We need you!

NOTICE IS HEREBY GIVEN THAT

**LYNN HUNTER**

New Democrat Candidate in Saanich-Gulf Islands riding HAS A CAMPAIGN OFFICE at 120 Hereford (THE FORMER LEGION) Office is open from 11 to 7 pm. Monday to Saturday until Nov. 22. Authorized by Peggy Mika, official agent for Lynn Hunter.

**Gulf Islands Woodlands Assoc. PUBLIC GENERAL MEETING**  
High School Band Room  
Monday, Oct. 17th — 7:30 pm.

**Notices**



**PAWS INN PET RESORT**

In-house care for cats and smaller dogs. Your pet is at home with us. 750 Long Harbour Rd. 537-5198.

New, effective, successful programs for: Quitting smoking, weight control, compulsions, anxiety. Ariadne Sawyer, M.A. Psych., Clinical Hypnosis. 537-2125 or 537-4556.

GANGES FISHERMEN'S ASSOCIATION

Annual General Meeting  
October 12th - 8 pm.  
Vesuvius Inn

Agenda: 1) Election of officers; 2) Wharfage concerns; 3) Planning annual fishermen's dance.

**WE'RE IN BUSINESS!**

We're just not in the book yet! Write our NEW number down now so you have it handy for all your heating/refrigeration or appliance repair needs.

GUARANTEED FAST & FRIENDLY RELIABLE SERVICE  
Mark Devereux  
G. I. HEATING & REFRIGERATION  
537-4027

**Burritt Bros.**

**CARPET CLEANING**

OCTOBER 20 - 22  
Truck mounted, steam extraction, cleaning method.

Call 537-2111 FOR INFO & ESTIMATES

LAKE OF THE MOON

**ROWING SCHOOL**

St. Mary Lake, Salt Spring Is.



Instruction in the use of recreational rowing shells for fun, exercise and relaxation. For information & rates call:

537-9756 or 537-5991

or write, Box 1375, Ganges, B.C. V0S 1E0.

**The Sierra Club**

is having a hike on Oct. 16th Out to find some old growth on the Island. We are hiking with Peter McAllister, Robert Andrew and Paul Linton. Meet 10 am. Drummond Park.

**ANNUAL GENERAL MEETING H.E.A.L.I. ALERT LINE SOCIETY**  
October 24, 1988  
4:30 pm. at School Board Office - Everyone welcome.

**TERRY FOX!**  
REMEMBER YOUR PLEDGES ARE DUE OCT. 21st.

**CHURCH NOTICES**  
Sun., Oct. 16

**Community Gospel Chapel**  
Drake Rd., Ganges  
Worship Service 10:30 am Sundays with Sunday School classes for the children.  
Evening Service 7:30 Bible Study & Prayer Thursday 7:30 pm  
PASTOR:  
Rev. S.F. Hildebrandt  
537-5757 537-2622

**Anglican Parish Salt Spring Island**  
St. Mark's, Central Holy Eucharist 11:15  
St. George's, Ganges Holy Eucharist 9:15 with Sunday School  
St. Mary's, Fulford Holy Eucharist 4 pm

**Weekday Eucharist: St. George's -**  
5:15 pm Thursdays  
Rev. James Koester  
Parish Office: 537-2171

**Ganges United Church**  
Hereford Ave., Ganges  
Worship Service 10 am with Sunday School for Nursery to 15 years  
MINISTER:  
Rev. Dale Perkins  
537-5812

**Catholic Church Salt Spring Island**  
Fulford - 9 am  
Ganges - 10:30 am  
Saturdays - Ganges, 5 pm  
Rev. Fr. P.A. Bergin

**Salt Spring Pentecostal Assembly**  
CENTRAL HALL  
Sunday School 9:30-10:15 am  
Morning Worship 10:30  
Thursday: Fellowship Nights 7:00 Home Meetings  
For more info call 537-4143  
Pastor: Jim Caruso  
Affiliated with P.A.O.C.

**Salt Spring Island Baptist Church**  
Admiral Hall  
506 Lower Ganges Rd.  
SUNDAY—  
Family Service 10:30 with Sunday School  
Eve. Fellowship 7:00  
TUESDAY—  
Family Night 6:30  
THURSDAY—ladies' Home Bible Study 9:30  
PASTOR:  
Rev. Brian Joyce  
537-2222

**Notices**

**Baseball Team Photos**

If you have not yet purchased your Salt Spring Island Minor Baseball team pictures, phone 537-9216 or find Barb Kinnear at Portlock on Saturday mornings between 9 and 11 am.

C.A.C. needs volunteers - see Arts page.

**Notices**

**Mycological Society**

forming within Gulf Islands for culinary mushroom identification and education. Please contact DEAN at 539-3129, Galiano Island.

Looking for a New Outlet?

**WATERFRONT GALLERY**

is accepting applications for new members. We are a member-owned gallery operating for over 10 successful years! CALL JUDI at 537-2015 for information.

**© ECKANKAR**

**"ANCIENT SCIENCE OF SOUL TRAVEL"**

"Soul - the real you - is eternal. You have lived before, and will live again." Quoted from "ECKANKAR - an Introduction". Read stories of students' experiences with Spirit in this free introductory booklet. Phone 537-4151.

Effective Nov. 1 - better service, extended hours in our new location on McPhillips Ave., next to the Library. Village Electronics, 537-4544.

**Notices**

**Islands Trust**

Ganges office (Government Building) will open on Thursdays from 1-3 pm. (instead of Mondays.) This time will coincide with the planner's visits to the island, and the new advisory planning commission dates. To allow for full Driftwood coverage of land use matters, the APC will meet on second and fourth Thursdays from 2:30 - 5 pm. at the Harbour House Hotel.

PLANNER: Dave Morris, 387-4005  
TRUSTEES: Pat Byrne - 537-4258 and Nick Gilbert - 537-5397.  
CHAIRMAN, APC.: Ian Fraser, 537-9849.

NEW HOURS DAILY:  
10 am. - 3 pm.

Coming Nov. 1 - 14th:  
"COUNTRY IMPRESSIONS"  
by A. Town

Works of FRITZ HUG are on display only at the FIELD MOUSE GALLERY 185 Arbutus Rd., Southey Bay Saltspring Island

**S.S.I. WORKSHOP CENTRE**

is offering space to anyone giving workshops. With or without accommodation. 653-9575

**Notices**

**S.S.I. Photographic Workshop Centre**

is accepting registration for 3-month commercial photographic programme. Class limited to 10 students. 653-9575.

DURASTILL - pure water done nature's way. The problem: Tap water has absorbed into it everything it has touched: organic (animal decay), inorganic (toxic pipe sludge, leads, sulfates, sodium, you name it). These materials deposit in our arteries, bone joints, etc. Drinking pure water carries these deposits out of the body. Takes the load off the immune system, you feel better.

Nature uses evaporation to purify water. Rain is pure water. However the environment pollutes it almost immediately. Distillation recreate mechanically what nature does naturally. Please write P.O. Box 1257, Ganges, B. C., VOS 1E0, for more information.

Workshop on Robert's Rules of Order and Public Speaking Skills, open to teachers and interested community members. SSE Library, Tuesday, Oct. 18, 4 - 7 pm. Sponsored by GITA Status of Women Committee. Details, Linda, 537-9928.

**Coming Events**

**CINEMA CLUB**

**Life is a Bed of Roses**  
Alain Resnais 1983. A crackpot Frenchman tries to remould the consciousness of his friends with a series of social experiments. This comedy should be easy for Salt Springers to identify with. 8 PM. CENTRAL HALL October 17th

**ATTENTION:**

**TRAIL & NATURE CLUB MEMBERS**

The visit to Wildwood Tree Farm in Ladysmith on October 18th has had to be postponed to November 8th. There will be an EASY WALK in the Crofton area on October 18th.

Watch for our menu in next week's paper - Ships Anchor Pizza (formerly DJs Pizza). 537-5338.

CPF - Canadian Parents for French, information and planning meeting tonight (Oct. 12th), at 7:30 pm. French Room, high school. Everyone welcome.

**Coming Events**



**IN THE GALLERY OPENING RECEPTION THIS FRIDAY**  
October 14, 7 to 10 pm. for "RAPE OF GAIA"  
Photo-etchings, photographs and monoprints by LYNDA LAUSHWAY with original music performed by DIANA DEAN & LYNN QUINN. Exhibit continues through Oct. 29.

GALLERY HRS.:  
Tues - Fri. 1 - 4 pm.  
\*\*\*  
WEEKEND WORKSHOP "REDISCOVERING THROUGH DRAMA" conducted by MARLA LEVENSTEIN

Uncover your gift of creativity through improvisation, storytelling, theatre games, art and movement. A playful approach for adults. SATURDAY, Oct. 15 - 7:30 - 9:30 pm. and SUNDAY, Oct. 16 - 11 am. - 5 pm. - \$35. For information & registration call 537-5211.

ROOTS ROCK REGGAE with AZAD  
SATURDAY, OCT. 15th  
Fulford Hall - All ages welcome  
Jamaican food & refreshments

**Coming Events**

SALT SPRING HYSTERICAL SOCIETY

**COMEDY NIGHTS**

FRI. & SAT., Oct. 21 & 22  
OFF CENTRE STAGE  
Get your tickets now at et cetera.  
OPEN STAGE COMICS:  
Call Off Centre to ask about auditions Sunday 6-8 pm.

**AUTUMN TEA**

ST. MARY'S GUILD  
at Fulford Harbour OAPO Hall  
Friday, Oct. 14th - 2-4 pm.  
Home baking, flowers, fruit & vegetables, attic treasures, knick knacks and books.

**Business Services**



Garden & Tree Service

LANDSCAPING  
FALL CLEAN-UP  
PLANTING  
COMPLETE GARDEN CARE  
Ellwyn McKague  
537-2723 - call evs.

**BUSINESS DIRECTORY**

**APPLIANCE SALES & SERV.**

Gulf Island  
**APPLIANCE & REFRIGERATION REPAIRS**  
MON-FRI 8:30-4:30  
Geoff Leason  
537-9243

**AUTOMOTIVE**

Saltspring Esso  
COMPLETE  
AUTOMOTIVE REPAIRS  
 537-4554  
OPEN 6 DAYS A WEEK  
8-6 weekdays, 8:30-5 Sat.

Like New Again!  
**DON IRWIN'S COLLISION & REPAIRS LTD.**  
Desmond Crescent  
537-2513

**MARCOTTE'S GARAGE**  
Stewart Rd. 537-9423  
● Autowrecking  
● All types of repairs  
● Used parts  
● Towing or Salvage  
● Welding  
TUESDAY to SATURDAY  
9 am to 5 pm

**CROFTON AUTO SERVICE**  
 246-3115  
Open 7 days a week  
7-8 Mon.-Sat. Sun. 9-5  
8314 Crofton Rd., Crofton

**CONSTRUCTION**

**Lancer Contracting Ltd.**  
● Commercial  
● Custom Homes  
653-4437  
Gerry or Jay  
653-4678  
Perry

**Peter Melancon Construction**  
Concrete, Framing, Finishing, Renovations & Additions  
Phone 653-4642

**D. A. Smith General Contracting Ltd.**  
NEW HOMES  
ADDITIONS  
RENOVATIONS  
FRAMING  
Large or small jobs, contract or hourly  
Phone 653-4695  
after 5:30 pm  
P.O. Box 1026, Ganges

**CONSTRUCTION**

**CONSTRUCTION SERVICES**  
● Custom Housing ● Renovations  
● Design Drafting  
● General Contracting  
● Construction Management  
537-5119



(enterprises Ltd)  
**'Stonework Specialist'**  
Masonry Contractor  
Richard Dakin  
537-4216  
Box 1122, Ganges

**ROOFING**  
Shake'n'Shingle  
RE-ROOF  
NEW  
REPAIRS  
● Free estimate  
● 5-year warranty  
● could save \$\$\$!  
**RON CALBERY**  
537-5948  
Serving all the Gulf Islands since 1981  
Box 1187, Ganges

**CONSTRUCTION**

**Walter Huser & Sons Construction**  
RESIDENTIAL & COMMERCIAL  
● Quality Homes  
● Additions  
● Designing  
● Renovations  
● Finishing Work  
30 YEARS EXPERIENCE  
537-2385  
537-5247  
Box 1398, Ganges, B.C.

What's holding you back?

*South End Construction*  
New Homes & Renovations  
General or Subcontract  
**PAUL ADAMS**  
653-4589  
Box 67, R.R. 1  
Fulford Harbour

**CONSTRUCTION**

*Villadsen Construction (1980) Ltd.*  
"QUALITY HOMES OF DISTINCTION"  
Box 441, Ganges, B.C.  
VOS 1E0  
SERVING SALT SPRING FOR 30 YEARS  
Telephone  
537-5463

**CONCRETE**

**GULF COAST MATERIALS**  
Serving the Gulf Islands:  
Salt Spring - Galiano  
Mayne - Penders  
  
● READY MIX  
● WASHED GRAVEL  
● REINFORCING STEEL  
● DRAIN TILE  
● BAGGED CEMENT  
● CONCRETE PRODUCTS  
● SCAFFOLDING RENTAL  
537-2611  
Rainbow Road  
Box 72, Ganges, B.C.

**DRYWALL**

**Drywall**  
Serving ONLY the Gulf Islands for 10 years.  
FREE ESTIMATES ON:  
● Renovations or new work  
● Residential or commercial  
DRYWALLING with machines  
INSULATING & vapour barrier  
TEXTURE ceilings & walls  
VINYL BOARD & STEEL STUDDING  
PRIMING of wallboard  
**SALT SPRING INTERIORS**  
Phone Brian Little  
537-2590  
Box 476, Ganges, B.C.

**ELECTRIC**

Residential AND Commercial  
  
**GUILBAULT ELECTRIC LTD.**  
Baseboard & Radiant Heating  
537-5675  
Box 181, Ganges, B.C.

**Business Services**

DOES YOUR CHIMNEY NEED CLEANING?

**HOGAN CHIMNEY SWEEPS**  
537-5340

CHIMNEY CLEANING  
STOVE & ACCESSORY SALES  
CHIMNEY INSTALLATIONS & REPAIRS

Professional Sweep  
Journeyman Mason  
20 years on Island



39-tfn

YOUR HOME DECORATING CENTRE:

- Drapery Fabrics
- Vertical and Venetian Blinds
- Woven Wood, Pleated & Roller Blinds
- Rod & Track
- Silk Plants
- Table Lamps
- Wallpaper
- ON SITE WORKROOM & INSTALLATION SERVICE

**Islander Drapery**  
10 - 3 pm. Mout's Mall  
537-5837

37-tfn

MacIsaac Clark & Co. 560 Johnson St., Victoria. Personal Injury Lawyers. Fees by %. First visit free. Phone 381-5353.

**Business Services**

TOM VOLQUARDSEN  
537-5188

P.O. Box 385,  
Ganges, B.C.  
V0S 1E0

WALLPAPERING & PAINTING



**OLDE COUNTRY UPHOLSTERY**  
offers over 30 years experience in domestic, antique and marine upholstery.  
537-4433 - 8 to 4:30 pm.  
Monday to Friday

28-tfn

**Crystal Beauty Clinic**

Now accepting appointments for facials, legwaxing, hair removal, deep pore cleansing, eyebrows, eyelash dyeing. Aromatherapy body massage. Hot mud wrap. Reiki Healing. Call 537-5379 and 537-2956

36-tfn

**Satisfaction Services**

CARPENTRY & PAINTING & CHIMNEY SWEEPING

CALL TED

537-2809

1st - \$22.50

Additional - \$11.25



**Business Services**

Computing Troubles? DON'T DESPAIR ...

Help with hardware and software acquisition and installation. Data recovery. General trouble-shooting. Reasonable rates.

CUSTOM MADE DRAPERIES

by **Marianna**  
FULL SELECTION OF VERTICAL & VENETIAN BLINDS  
Fabrics, Decorator Rods & Tracks



537-9592

33-tfn

**Too Late to Classify**

NOTICES  
Terry Fox run money should be into a chartered bank by Oct. 21st. Please do your best to meet this deadline. Your support is greatly appreciated!

41-2

ANNOUNCEMENTS  
Win a Royal Viking Cruise for 2 Hong Kong to Honolulu, Dec. 4 - 20. Tickets \$2 ea. or 6 for \$10. Available at Community Centre and et cetera.

37-tfn

**Real Estate for Sale**

**Brown Bros.**  
ON BLANSHARD

385-8771

SALT SPRING ISL.

Fabulous location and quick possession on this choice property. Only 5 miles from Fulford Ferry, vacant, comfortable 2 bdrm. home plus large barn for sheep, shed and 'A'-frame cottage. Almost 8 acres with sunny exposure hay field land. Numerous fruit trees. Relaxing setting. Hurry to see \$118,000 MLS. 24863. Olga Zachary 592-2265, Victoria.

**Too Late to Classify**

NOTICES  
Working late? How about a Pizza for dinner? Ships Anchor Pizza (formerly D.J.s Pizza). Eat in or take out. 537-5338.

1

NOTICES  
The move is on - November 1st. See us in our new location on McPhillips Ave., next to the Library. Village Electronics, 537-4544.

1

NOTICES  
C.A.C. needs volunteers - see Arts Page.

**Legal**

NOTICE TO CREDITORS AND OTHERS  
IN THE MATTER OF THE ESTATE OF GRAYDON EMBREE, also known as GRAYDON LEROY EMBREE, Deceased

NOTICE IS HEREBY GIVEN that creditors and others having claims against the Estate of Graydon Embree, also known as Graydon Leroy Embree, Electrician, late of 4800 Clinton Street, South Burnaby, British Columbia, are required to send full particulars of such claim to Williams, Davie & Company, 170 Craig Street, Duncan, British Columbia, V9L 1W1, on or before the 9th day of November, 1988, after which date the Estate's assets will be distributed having regard only to claims that have been received.

HILDA CHARNOCK EMBREE and BRIAN EMBREE, Executors  
By their solicitors WILLIAMS, DAVIE & COMPANY  
170 Craig Street, Duncan, B.C. V9L 1W1

20-2

**Too Late to Classify**

WANTED  
In good condition, old sewing box with 2 fold-out accordion-type drawers. Stands on 4 legs and about 2 feet high including handle. Days 537-5011 or eves. 537-2033.

1

APPLICATION FOR A WATER LICENCE

WATER ACT (Section 8)  
We, Gordon and Valentina McEwan of R.R. 1, Chu-Ann Drive, Comp. 30, Ganges, B.C. V0S 1E0, hereby apply to the Comptroller of Water Rights for a licence to divert and use/store water out of St. Mary Lake which flows West to Stuart Channel and discharges into Stuart Channel and give notice of application to all persons affected.

The quantity of water to be diverted or stored is 500 gallons a day for an average 3 bdrm. house. The purpose for which the water will be used is for domestic (household) use. The land or mine on which the water will be used is Lot 6, Section 10, Range 1 East, North Salt Spring Island, Cowichan District, Plan 6199. A copy of this application was posted on the 2nd day, Sept., 1988, at the proposed point of diversion or site of the dam and on the land or mine where the water is to be used and two copies will be filed in the office the Water Recorder at Water Management Board, 2569 Kenworth Rd., Nanaimo, British Columbia. Objections to this application may be filed with the said Water Recorder or with the Comptroller of Water Rights, Parliament Buildings, Victoria, B.C. V8V 1X5, within thirty days of the serving of a signed copy of the application.

Gordon McEwan and Valentina G. McEwan

41-2

**BUSINESS DIRECTORY**

**EXCAVATING**

**HEDGEHOG**

BULLDOZING & EXCAVATING LTD.

We Shape The Islands

- Excavators ● Gravel Trucks
- Backhoes ● Loaders
- Gravel ● Crushed Rock
- Estimates ● Topsoil
- Fill ● Shale

LAURIE A. HEDGER  
PATRICK BYRON

Box 156, Ganges, B.C. V0S 1E0

537-9311

**Ken Byron Excavating**

Septic Tanks & Fields Supplied & Installed

537-2882

**G. & L. Excavating Ltd.**

- Land Clearing
- Road Building
- Driveways
- House Excavations
- Water & Sewer Systems
- Ponds
- Trucking

537-5176

**EXCAVATING**

**Matthews Bobcat Service**

- Septic Fields ● Ditching
- Landscaping
- Driveways ● Backfilling

537-5724 eves.

**GARBAGE COLLECTION**

SALT SPRING GARBAGE COLLECTION SERVICE

537-2167

**Gulf Islands Septic Ltd.**

Septic tank pump-outs

537-9353

**HEATING OIL**



Salt Spring Petroleum

- Furnace Oil
- Stove Oil
- Marine Fuels
- Commercial Fuels & Oils

537-5331

**Bruce Fiander**  
YOUR IMPERIAL



AGENT 537-5312

Box 347, Ganges, B.C.

**INSURANCE**

Motor Vehicle Office

**INSURANCE**  
ALL CLASSES OF INSURANCE

Salt Spring Insurance Agencies (1972) LTD.

OFFICE HOURS:  
9 am-4:30 pm, Mon.-Fri.

537-5527

P.O. Box 540, Ganges, B.C.

**JANITORIAL**

**ME & EWE**  
Janitor & Security Services

- Residential - Commercial
- Carpet & Upholstery
- Steamcleaned SCOTCHGARD
- Windows

537-2946

**Gulf Island WINDOW CLEANERS**

Janitor Service

Carpets Steam Cleaned

We also offer Carpet Guard Treatment

537-9841

**PAINTING**

**PAINTING & DECORATING**

TOM VOLQUARDSEN  
537-5188

**Kevin C. Marks**

PAINTING WALLPAPERING & DECORATING

"Quality Work at Reasonable Prices"

537-4594

**PLUMBING & HEATING**

**Roy W. Wheatley PLUMBING**

Water & Effluent Pumps SERVICE WORK A SPECIALTY  
537-2722  
Box 898, Ganges, B.C.

**Plumbing & Pumps**

DAVID RAINSFORD  
653 4494 residence  
537-2013 shop

**ISLAND PLUMBING**

Plumbing, Pumps, Hot Water Heating COMMERCIAL RESIDENTIAL  
DERRICK BRAZIER  
537-5332

**DON'T LET WILDFIRES BE YOUR FAULT**



**RODERICK MACDONALD PLUMBING SERVICES**  
★ RENOVATIONS ★  
★ NEW CONSTRUCTION ★  
★ WORK GUARANTEED ★  
537-5278

**J & A Oil Burner Service**

JOHN COTTRELL  
Certified Oil Burner Mechanic  
BOX 226 GANGES 537-9314

**REAL ESTATE**

**NRS NATIONAL REAL ESTATE SERVICE**

PAUL GREENBAUM  
★ Residential  
★ Recreational  
★ Commercial  
★ Free market evaluations  
★ Free catalog  
537-5064 537-5515

**TELEVISION & STEREO**

**TV-VCR-STEREO REPAIR SERVICE**

Local pick-up & delivery All makes In-shop estimates Hours: Mon.-Fri. 9-5  
J.P.-TV  
537-9811  
141 Salt Spring Way



**Eckstein's Designs**

226 Fulford-Ganges Rd.  
SERVICE & CRAFTSMANSHIP IN GLASS & METAL

- Windows & Patio Doors
- Residential and Commercial
- Mirror Walls
- Room Dividers
- Skylights & Solariums
- Shower Enclosures
- Fire-Proof Glass
- Stained Glass Windows
- Etching in Glass
- Light Fixtures
- Design Service

HAND FORGED CUSTOM IRON WORK  
Adolf & Karen Eckstein

537-4545

Box 312, Ganges, B.C. V0S 1E0

**OOPS—**



Locked your keys inside?

**Keeper Locks**  
Now Open on Salt Spring KEYS CUT

Locks sold, serviced, installed Automotive, Household, Commercial Prompt Bonded Service  
537-2032 days  
653-4293 eves.

# Concerns

Sir,  
About 225 residents of the Duncan area attended the meeting last week concerning the Crofton mill, with a panel of experts who repeated much of what was said here last May. Renate Kroesa of Greenpeace was back from the European conference on dioxins and gave details on how the European markets are switching to support a dioxin-free environment. The industry rep just waffled on remarks and questions; the federal rep didn't show up.

Questions from the floor reflected a wide variety of genuine concerns. The five women sitting behind me were there because each had lost a baby or relative from cancer and were wondering what

the connection was. (Apparently 20 people living within two miles of the mill have died of cancer.) Efforts are being made to study their situation.

The following day, the overall pulp and paper mill situation was discussed at a coalition meeting in Vancouver. It seems there are two types of mills; type A empties into fresh water lakes and rivers; type B, the coastal mills just dumps everything into coastal waters.

Jacques Cousteau apparently predicted that this whole area, with six mills emptying into it, was

destined to become 'like a sewer.' Terry Jacks, advocate for West Vancouver and the Squamish area said that on a given day you'll find 60 fishermen fishing for Vancouver restaurants in Howe Sound, off the outfall from the Port Mellon mill, which registers 33 times the safe level of dioxin. And the Department of Health and Welfare posts no signs.

This also raises the question of the Vietnamese, who clean these dioxin-filled beaches for clams for their restaurants, with no enforcement.

At the end of the month, the pulp and paper mill industry will be meeting in Vancouver. We'll see what transpires.  
**SUE HISCOCKS,**  
Ganges.

## Thank you

Sir,  
The Salt Spring Island Pre-School would like to thank everyone who helped with our sale of fresh-pressed apple juice at the Fall Fair.

Delicious apples were generously donated by Mrs. Agnes Baker, Shirley and Donald Baker, the Farmers' Institute, Mrs. Murakami, Fulford Marina and an anonymous person who dropped off a load for our use.

We would also like to thank Foxglove Farm and Garden Supply, who provided the press, as well as Embe Bakery, the Fulford Inn and Dave Waldie, who provided various buckets and jugs.

Finally, a big thank you to all members of the community who supported us by purchasing apple juice by the glass or in bulk. All proceeds will be used to improve our preschool.  
**LINDA ADAMS,**  
Salt Spring Island Pre-School.

### Deaths

**FRY - Stuart (Stu),** born in New Westminster, B.C. and a 20-year resident of Mayne Island, passed away peacefully in his sleep on October 6, 1988, aged 77 years. Survived by his loving wife Betty, his daughter Norma Roberta Gray, of Oliver, B.C., his sons Glenn Roland Fry, of New Westminster and John Allan Fry of Stockholm, Sweden, many grandchildren and great-grandchildren. Stu was a life member of the B.P.O.E. (Elks). At Stu's request, no formal service will be held. In lieu of flowers, donations may be made to the Canadian Cancer Society.

### Too Late to Classify

**FOR RENT**  
For single person, lower level 2-room suite near Vesuvius. One large room with stove, fridge, dining area. Studio room with skylights, windows, cupboards, deck, south facing water view. \$250/month plus hydro. Available November 1. 537-2949 evenings.

### NOTICES

Tools for Peace—Nicaraguan priorities this year are school supplies, safety equipment (goggles, masks, gloves, etc.), rubber boots (max. size 8), basic tools, roofing. Collection boxes at Gulfstream, KIS, et cetera, United Church and Foxglove. Cash donations for roofing at market table or Tools for Peace, Box 1500, Ganges, B.C. V0S 1E0, phone 537-4347.

### CARS, TRUCKS

1981 Plymouth Caravelle wagon (mid-size), 45,000 miles, small V-8 auto, radials, \$3,800 OBO. Evenings 537-2590.

### MOBILES, TRAILERS

1976 Winnebago 20' class C motorhome, clean, well-maintained, 59,000 miles. New radials and exhaust system, extra large RV battery, storms for all coach windows, sleeps six, just serviced, ready for road. 537-2889.

### WANTED

In good condition, chesterfield and chair in velour upholstery with white background and red floral design. Please phone 537-4349.

### WANTED

Wanted—reliable, clean, economical older car. Please call 537-2858 or 537-4588 to leave message.

### FOR SALE

2 single wooden beds with mattresses, \$60 each OBO. 653-4355.

### CARS, TRUCKS

-75 Datsun 4-dr. station wagon in good condition, \$1500 OBO. 537-2239.

### BIRTHS

It's a boy!! Dr. Michael Buna and wife Joan are very proud to announce the arrival of Ryan J. Steven Soukerefry Buna. All are healthy and very happy!

### Too Late to Classify

#### NOTICES

Friday, Oct. 14, is United Nations World Food Day at GISS. Theme—Jamaican Relief. Wanted—donations for Jamaican Relief and Tools for Peace, of children's clothing, blankets, notebooks, etc. Entertainment—Raging Granies, Oscar Riley, Sandy Johnson. Goal—to encourage global awareness. Community welcome.

#### CARS, TRUCKS

1975 Ford pickup, new trans, good body, motor needs repair. \$600. Call Mike 537-4144.

#### FOR SALE

Fresh cut alder firewood for the do-it-yourselfer. We cut, you haul, you split. \$35 a full size pickup without extra sides. 537-2801.

### Too Late to Classify

#### FOR SALE

Fresh frozen salmon. Call Beth 653-9359.

#### FOR SALE

Fraser's Thimble Farm, 175 Arbutus Rd., Southey Pt., 537-5788 - open 10 am-4:30 pm, 7 days a week. All bulbs in stock 20% off - 4" heather, many varieties, \$1.79 ea. or 3/\$5 - ornamental winter cabbage 99¢ ea. - winter pansies, pink forget-me-nots & wallflowers.

#### WORK WANTED

Journeyman carpenter available for work. Additions, renovations, sundecks, new construction, concrete work, drywall, custom finishing, etc. Specializing in rafter and stair work. Quality and integrity. Reasonable rates. References. 653-4457.

### Too Late to Classify

#### NOTICES

Under the Rainbow Nursery School presents a Concert for Children, Sat., Oct. 22, 1 pm, Mahon Hall. Songs, puppets and finger plays by Lisa and friends. \$1 per person at the door.

#### NOTICES

Minor baseball general meeting, new members welcome. Wed., Oct. 19, 7 pm, Salt Spring Elem. Library. Call 537-9216.

#### FOR SALE

Washing machine, good running order. \$250. Call Ann 537-2284 eves., 537-9981 days.

#### FOR SALE

1978 Honda Twin Star motorcycle, model #CM185, runs well. Nice light street bike. \$300 OBO. 653-4609.

### Too Late to Classify

#### FOUND

Child's jacket found Monday, Oct. 10, at Centennial Park. Call 537-4590.

#### CARS, TRUCKS

'75 Dodge Colt, good running condition, \$300. 653-4287 after 6 pm.

#### FOR SALE

Fender guitar, 12-string acoustic, hard case, mint. \$450. 537-5474.

#### CARS, TRUCKS

1977 Ford 1 ton flat deck with sides, runs well, \$2,500 OBO. Will trade truck and cash for 80's 3/4 T supercab. 537-5096.

#### ANNOUNCEMENTS

Happy 40th anniversary Kurt and Esther Hengstler! Love, Butch, Cheezel, Tigger and Snakel

### Too Late to Classify

#### FOR SALE

Canada! Don't sell it. Buy Judge Bowker's report at et cetera.

#### BUSINESS SERVICES

Hairdressing services in your home. Serving Fulford and Ganges. Perms \$30-\$35. Shampoo sets \$9. Haircuts \$9. Special rates for senior citizens. For appointment, call 653-9459.

#### WORK WANTED

Do you want to improve your French? Lessons for everyone. Children, students and adults welcome. \$10 per hour. Phone after 5 pm for information. 653-9459.

#### FOR SALE

Older Singer sewing machine, recently reconditioned. 1930's? \$50. 653-9518.

## BLANKET CLASSIFIED ADVERTISING

These Ads appear in the more than 75 Newspapers of the B.C. and Yukon Community Newspapers Association and reach more than 1,000,000 homes and a potential two million readers.

**\$159. for 25 words (\$3. per each additional word)**

### AUTOMOTIVE

Trucks, Trucks, Trucks. Diesel, Gas, Propane. Lease, Purchase, Trade. Pickup Hi-way haul. Call for last best price. Bob Langstaff, Norm Diederich 327-0431. Free Delivery.

Free information on how to save gas mileage, increase power and decrease pollution in 80% of all motor vehicles. Not good for diesel engines. Write to: "Fuel Kit", Box 3423-6c, Mission, B.C. V2V 4J5.

Buy/lease any gas, diesel car or truck, new or used. Direct from volume factory dealer. Call for pre-approved credit. Call collect 464-0271. D5231.

### BUSINESS OPPORTUNITIES

For Sale: Passive Exercise Salon. Seven toning tables. Easy to operate family business showing good returns. Call (604) 493-3939 or 494-8683. Ask for Pauline.

Start a mail order home business. Easy, profitable. Sell information by mail. Books, newsletters, courses. We drop-ship. Details: Garant, Box 2895WF, Thunder Bay, Ont. P7B 5G3.

Maytag home style coin-laundry store franchises. Exciting new proven concept for making money. Spectacular growth potential. Your own recession proof business. Western Maytag 438-6294.

Barley Green, plus four other superior health foods. Distributors wanted. Obtain financial independence in MLM. Write: Mary Yadlos, Box 11, Ponoka, Alta. T0C 2H0. 1-(403) 783-3466.

### BUSINESS OPPORTUNITIES

Highly profitable home business you can start in your spare time with limited funds, plus success secrets. Free details. Rush business size S.A.S.E. to Progress International, 43 - 600 Falcon Drive, Port Moody, B.C. V3H 4E1.

Ambitious, self-motivated people with desire to succeed and earn serious money urgently required. New proven business. Apply: TMC, 2133 Panaview, Saanichton, B.C. V0S 1M0. 652-0289.

Be sure to attend the largest International Franchise and Dealership Exhibition. See and meet in person a complete selection of Leading Business Opportunities. Full and Part-time. Investments from \$50 - \$150,000. Friday October 21, Noon to 6:00 p.m. Sat/Sun October 22 and 23, 10:00 a.m. to 6:00 p.m. Sheraton Landmark Hotel, 1400 Robson Street, Vancouver. Admission \$10. per person. For information call 687-2900.

Motel Sale Urgent. Super Merritt location, reputation, condition!!! Asking price reduced to \$425,000. Gross sales \$158,000, low overhead costs. Opportunity of a lifetime!!! Must sell situation. Information: Art Ducommun, 596-5161, Lakeview Realty. 588-9955 messages.

Start your own Import/Export mail order business, even spare time. No money or experience. Since 1946. Free brochure: Wade World Trade, c/o Cdn. Small Business Inst., Dept. W1, 1140 Bellamy Road N., Scarborough, Ont. M1H 1H4.

### BUSINESS OPPORTUNITIES

Ma Cherie Fashions (Est. 1975). Discover a new rewarding career. Be an independent. Join our team. It's the fun easy way to earn extra money. Call Collect (416)827-2660.

Start A Second Career! Learn tax preparation or basic bookkeeping. For free brochures, no obligation: U & R Tax Services, 1345 Pembina Hwy., Winnipeg, Man. R3T 2B6. (204) 284-1806. Franchises available.

### EDUCATIONAL

Learn The Secrets Of Chording On Guitar. New home study course. Fast, easy method. Guaranteed! For Free information, write: Popular Music Systems, Studio 15, 3284 Boucherie Road, Kelowna, B.C. V1Z 2H2.

Free: 1988 guide to study-at-home correspondence Diploma courses for prestigious careers: Accounting, Airconditioning, Bookkeeping, Business, Cosmetology, Electronics, Legal/Medical Secretary, Psychology, Travel. Granton (1A) #2002 - 1055 West Georgia Street, Vancouver. 1-800-268-1121.

### FOR SALE MISC.

Lighting Fixtures. Western Canada's largest display. Wholesale and retail. Free Catalogues available. Norburn Lighting Centre., 4600 East Hastings Street, Burnaby, B.C. V5C 2K5. Phone 1-299-0666.

Storage Problems? Used steam ship containers, 8' x 8' x 35' long, insulated and in good condition. Call Lorne or Linda at (604) 530-7318.

### FOR SALE MISC.

Must be sold. Components of disassembled building suitable for warehouse, Hayshed, etc. Trusses, posts, metal cladding and decking 40' x 386' long x 12' high \$25,000 O.B.O. Call Richard 273-9011, 800-972-9973.

### GARDENING

Greenhouse and Hydroponic Supplies. Best selection and pricing in Canada. Same day shipping. Toll free order line 1-800-663-5619. Western Water Farms, 1244 Seymour Street, Vancouver. Call for our catalogue.

### HELP WANTED

Residential Building Managers required all over Canada. Completion of Government approved Correspondence Course qualifies you for these jobs. Guaranteed Placement Assistance by Munday Personnel. Call RMT1, 681-5456 or write for details 901 - 700 West Pender, Vancouver, B.C. V6C 1G8.

"Lease operators/brokers". Job opportunities across Canada w/reputable trucking companies. Accounting services monthly or annually. Licensing and permits. Consulting services. Extended Medical, Dental and Group Life Insurance. For more information please contact: Transpo Services Ltd., Wayne or Christina (604) 946-8801 or 1-800-663-5609.

Overseas Positions. Hundreds of top paying positions. All occupations. Free details. Overseas Employment Services, Dept. CA, Box 460, Mount Royal, Quebec. H3P 3C7. Call toll-free 1-800-361-2461.

### HELP WANTED

Wanted Immediately: EEC-1V Certified Ford automotive technician. Send complete resume to Box 45681, c/o Chilliwack Progress, 45860 Spadina Ave., Chilliwack, B.C. V2P 6H9.

Brilliant opportunity! Sell beautiful home decorator products by party plan. Part or full time. No Stock! No Delivery! Contact JoAnn (306) 228-3000.

Lawyer Associate with experience in litigation and general practice required. Salary negotiable. Reply to Douglas N. Best, #102 - 220 Oliver St., Williams Lake, B.C. V2G 1M1. 398-7001.

### PERSONAL

Would you like to correspond with unattached Christian people in Canada/USA with the object being companionship/ marriage. Write to Ashgrove, Box 205, Chase, B.C. V0E 1M0.

### SERVICES

"ICBC Offered me \$3,500. Carey Linde got me \$194,000." G.N. - Abbotsford. Vancouver Lawyer Carey Linde (since 1972) has Free Information. Phone 1-684-7798. Second Opinions Gladly Given.

ICBC Injury Claims? Call Dale Carr-Harris - 20 years a trial lawyer with five years medical school before law. 0-669-4922 (Vancouver). Experienced in head injury and other major claims. Percentage fees available.

Get a complete Divorce 5-15 weeks. Just \$69.95 plus Court Costs. Processing extra. No court appearance. No consent of spouse necessary. Eligible?? Find out Free Information and Divorce Act!!! Divorcercise 687-2900, 201 - 1252 Burrard, Vancouver, B.C. Same system since 1970.

## your garden

by chris schmah



It's almost too good to be true, but the weather over the past week has been more reminiscent of early September than the second week of October. With Thanksgiving happily tucked under our belts, and the autumn colours just starting to show, we still have plenty of sunshine and warm temperatures to make working out in the garden a truly pleasurable event.

Last week's article focused on aspects of the care and cultivation of fall bulbs, and this time around I would like to offer some suitable bulb selections for various special sites, or problem situations.

The first and most problematic bulb selections are the deer-proof or deer-resistant choices. The Alliums, members of the onion family, have a disagreeable flavour for deer, and are represented by a few blooming beauties including: *A. moly luteum*, with its late spring, golden yellow blossom head; *A. Karataviense*, showing a rich pink coloration; *A. neapolitanum*, presenting creamy white blooms; *A. giganteum* with its three-to-four-foot-high ball of small mauve flowers; and several others worthy of consideration, too.

The fall-blooming colchicums, which look like crocus flowers, have been in bloom for several weeks, and come in singles and doubles with shades of pink or white being available. Colchicums are poisonous, so they have a built in deer repellent. Glory-in-the-snow (*Chionodoxa*), in all of its species and colours, puts forth its delicate, starry blooms early in the spring and naturalizes well in rockeries, borders, under trees and shrubs in sun or partial shade. *Camassia cusikii* and other species will bear their rich purple and blue flower spikes in inhospitable clay soils that are saturated with water all winter, and dried hardpan all summer.

All Crocus species and varieties are deer-resistant, sometimes being sampled, but their early, delightful showing is worth taking a chance for. The yellow-blossomed winter aconites (*Eranthis*) will give a cheery showing in February and early March, doing especially well in woodland or orchard settings. The Fritillaria genus with its *F. imperialis* giving golden or orange flower clusters in early spring, *F. persica* with its blackish purple bloom spike, and *F. meleagris* with its purple and white checkered, nodding blooms, all contain something disagreeable which repels deer.

Snowdrops (*Galanthus*) in single and double forms give a delightful showing so early in the spring that they often push their way up through the snow. Later in the season, the summer snowflake (*Leucojum aestivum*) gives a taller, but similar-looking blossom which is also deer-resistant. The grape hyacinths (all *Muscari* species) and the *Scilla* genus (bluebells) are all deerproof and delight the eye when planted around the bases of trees and shrubs, or set out in woodland settings to naturalize in drifts.

Another bulb, actually planted out in the spring but also considered deerproof, is the Mexican shellflower (*Tigridia*). The final, largest and undoubtedly most-used group is the *Narcissus* genus including both narcissi and daffodils, with its wide range of blooming times, heights and colours in various combinations, flower styles and with fragrance too. While there may be an addition or two, and a couple may fall victim to deer sampling, that essentially is the deerproof list.

Another list which needs to be dealt with is one of bulbs for moist or seasonally wet soils. A good one for naturalizing along stream margins and heavy-textured soils is *Fritillaria meleagris*. For more open areas, *Camassia cusikii* is suitable, as is *Narcissus "Fortune"*. For the wet rockery and small scale, *Narcissus bulbocodium* will give a delightful showing in mid-spring. Summer snowflake will also do well in seasonally wet soils, both in sun and partial shade. Many of the narcissi and colchicums will tolerate a wet, heavy clay soil which stays saturated most of the winter, but dries off in summer (provided the water isn't stagnant).

For dry soils which won't get any irrigation during the growing season, a few selections are worthy of consideration. Aconites, anemones (blanda and St. Brigid), colchicums, crocus, cyclamen, daffodils, *Galanthus* (snowdrops), bluebells (*Scilla*), Oxalis, Iris (rhizome and bulbous types), hyacinths, tulips and narcissi will all flourish and flower provided they receive sufficient water during the spring growing and blooming period.

For shaded locations the list is as follows: anemones, cyclamen, crocus, erythronium (fawn lilies and trout lilies), summer snowflake (*Leucojum*), *Zantedeschia* (calla lilies), oxalis, chionodoxa, winter aconites (*Eranthis*), snowdrops (*Galanthus*), bluebells (*Scillas*), some narcissi, lily of the valley (*Convolvulus*) and for high shade situations with lots of room, hardy lilies (*Lilium*).

For all situations and problem areas, a selected bulb should be planted on a trial basis, and if blooming and growth continue then further plantings may be considered. If, on the other hand, the bulb fails to make a showing of flower the second year, or if growth slows, and vigour drops, then lift and move the bulb during its dormant season to a less severe location.

## Education value eyed

The scope and direction of teacher education should be studied in B.C., the Gulf Islands School District says.

Meeting on Saturna Island last week, trustees responded to a recommendation by the Royal Commission on Education in B.C. by calling for a study on the value of training given to teachers.

The Royal Commission study recommended that all teachers in the province hold a bachelor's degree. Local trustees, however, noted there is no evidence outlining what the degree accomplishes, and nothing that says holding one makes a person a better teacher.

Board chairman David Eyles told *Driftwood* there is even some dissatisfaction among teachers — and student teachers — about the value of the training they received en route to earning their degrees.

"So we feel a study should be done, to make it clear what is being accomplished and how valuable the training is," Eyles said.

The school district will ask its provincial body — the B.C. School Trustees Association (BCSTA) — to propose a study to an education ministry council following up the recommendations of the Royal Commission report. The BCSTA is a member of that ministry council.

## PHYLLIS W. TATUM R.S.W. COUNSELLOR IN PRIVATE PRACTICE

Tuesdays through Thursdays by appointment

537-4315

P.O. Box 1332  
Ganges, B.C. V0S 1E0

## FULFORD HARBOUR \$85,000

Character home on 1.7 acres across from Fulford Marina. Walk to schools, ferry & shops.



CONTACT: DENNIS O'HARA  
653-4633 or 537-5515

NRS Salt Spring Realty Ltd.  
Box 69, Ganges, B.C.  
V0S 1E0

We're celebrating our 10th year  
with a

# FREE MOVIE

Come & see Woody Allen's  
**ANNIE HALL**  
(our first ever film, Oct. 13, 1978)  
Saturday & Sunday, Oct. 15 & 16 8 pm  
Central Hall

## Island Cinema

Free Popcorn Too! CU at the Movies!

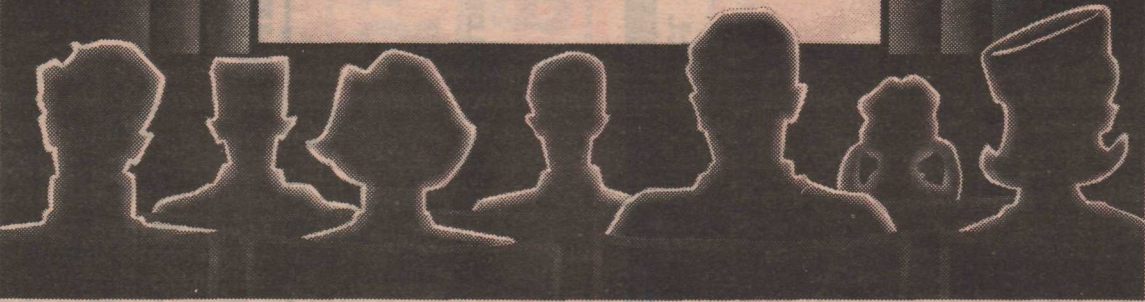

## ALTYPE CONSTRUCTION SERVICES LTD.

SERVING THE GULF ISLANDS  
AND VANCOUVER ISLAND

INSTALL MOORAGE BUOYS  
DOCKS / RAMPS / FLOATS  
BREAKWATERS / RETAINING WALLS  
PILE DRIVING / CONCRETE  
CRANE SERVICE / WELDING & FABRICATING

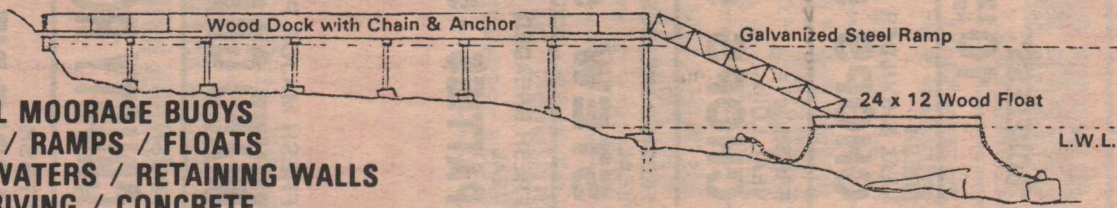

If you are in need of any docking facilities or repairs, let's talk — estimates are free! Phone COLLECT now — Chris Williams, 656-7081.



# Atlin visit gives view of northern settlement

**By FRANK RICHARDS**  
 An island of water entirely surrounded by land. That's Atlin, British Columbia, so far north that you never clearly establish in your mind whether you are in B.C. or the Yukon. Not that it matters too much, for they have a lot in common.  
 Atlin was the golden magnet that drew many a miner and many a prospector from the rich creeks of the Klondike. And again, like

the Yukon, modern methods of delving for gold have taken over and in both segments of golden Canada only the Cat is King.  
 I was in Atlin for a brief holiday to mark the end of summer. With two companions I meandered through the town that is striving to shed its burden of ghosts and gold rush and to find a new prosperity.  
 Everybody has heard of Atlin. Politically, it is a tale of tragedy. Disappointment and death have

haunted its political life. Within a decade the small northern community has been represented in Victoria by a native Indian, Larry Guno, and by a man who crossed the floor from the New Democratic opposition benches to the warmth of the government side, Al Passerall. The tragic death of Passerall established the constituency in the minds of British Columbians who might well have otherwise believed the

community a part of the Yukon. Historically, it burst into fame and fortune when gold was discovered, at the close of the 19th Century, among the nearby creeks. The discovery gave its name to a prosperous town, Discovery, a few miles from Atlin. All that remains of that prosperous town are one or two derelict shacks and an impressive monument of bare gravel. Discovery was born of Pine Creek gold and when Pine Creek

# Save the Family Way

Prices Effective Tues. to Sat., Oct 11 to Oct. 15, '88

**TUESDAY TO SATURDAY**

AD SPECIALS IN EFFECT ALL WEEK

**GORGE SHOPPING CENTRE**  
 OPEN DAILY 8-10 p.m. SUNDAYS 8-7 p.m.  
 272 GORGE RD.

**TOWN & COUNTRY CENTRE**  
 OPEN DAILY 8-10 p.m. SUNDAYS 8-7 p.m.  
 3555 DOUGLAS

**CANWEST MALL, LAMERO**  
 OPEN DAILY 9-9 p.m. SUNDAYS 9-7 p.m.  
 2945 JACKLIN RD.

OPEN 7 DAYS A WEEK! WITH FULL SERVICE . . .

## MEATS, POULTRY & SEAFOOD

<b>FRESH VEAL CUTLETS</b> "BONELESS" 10 <sup>12</sup> kg 4 <sup>59</sup> lb.	<b>PORK SHOULDER PICNIC</b> FRESH Shank Halves 1 <sup>94</sup> kg 88¢ lb.	<b>BEEF BLADE ROAST</b> G "A" 2 <sup>60</sup> kg 1 <sup>18</sup> lb.	<b>CHICKEN LEGS</b> "FRESH" POLY BAGGED 2 <sup>09</sup> kg 95¢ lb.
<b>FRESH VEAL SHOULDER CHOPS</b> 2 <sup>49</sup> lb.	<b>SCHNEIDER'S WEEK</b> ★	<b>OLD FASHIONED BONELESS HAM</b> 7 <sup>49</sup> lb. 3 <sup>49</sup> lb.	<b>CAN. GR. "A" BONELESS CROSS RIB ROAST</b> 4 <sup>14</sup> lb. 1 <sup>88</sup> lb.
<b>FRESH VEAL LOIN CHOPS</b> 9 <sup>46</sup> kg 4 <sup>29</sup> lb.	<b>SLICED BACON</b> 500 g pkg. 1 <sup>99</sup>	<b>VACUUM PACK WIENERS</b> 450 g pkg. 1 <sup>69</sup>	<b>SMOKED FAMILY PACK PORK SPARERIBS</b> 2 <sup>62</sup> kg 1 <sup>19</sup> lb.
<b>FRESH BONELESS STEW</b> 5 <sup>49</sup> kg 2 <sup>49</sup> lb.	<b>OCTOBERFEST SAUSAGES</b> 500 g pkg. 2 <sup>49</sup>	<b>ASSORTED MEAT PIES</b> 250 g pkg. 1 <sup>29</sup>	<b>CHICKEN LIVER</b> 450 GRAM TUB 39¢
<b>FRESH BREADED PATTIES</b> 5 <sup>05</sup> kg 2 <sup>29</sup> lb.	<b>OCTOBERFEST MUSTARD</b> 175 mL jar 2 <sup>29</sup>	<b>SAUSAGE ROLLS</b> 500 g pkg. 2 <sup>29</sup>	<b>QUICK FROZEN HEADLESS PRAWNS</b> 2 kg box 10 <sup>99</sup>
	<b>OCTOBERFEST SAUERKRAUT</b> 540 mL pkg. 1 <sup>19</sup>	<b>ASSORTED QUICHE</b> 250 g pkg. 1 <sup>29</sup>	
	<b>SHEPHERD'S PIE</b> 175 g pkg. 99¢		

## BAKERY FIBESH!

<b>FRESH MAJOR PLUS MIXED GRAIN BREAD</b> 680 gram loaf 1 <sup>48</sup>	<b>FRESH CRUSTY ROLLS</b> 12s pkg. 98¢	<b>FRESH APPLE PIE</b> 8 inch each 1 <sup>98</sup>	<b>FRESH BUTTER TARTS</b> 6s pkg. 1 <sup>58</sup>
---	--	--	---

"NEW" AT TOWN & COUNTRY LOCATION

**BULK FOODS** SCOOP and SAVE  
**BULK POP** 24 ASST. FLAVOURS  
 "SAVE MONEY OVER PACKAGE FOODS"

## FULL SERVICE DELI

**KOHLER'S EUROPEAN HAM** 79¢

## FRUITS & VEGETABLES

<b>B.C. GROWN FRESH BROCCOLI</b> 1 <sup>08</sup> kg. 98¢	<b>IMPORTED SHADY OAK FRESH MUSHROOMS</b> 3 <sup>92</sup> kg. 1 <sup>78</sup> lb.	<b>WASHINGTON, CANADA NO. 1 GRADE 3 SNAPTAP CARROTS</b> 72¢ lb.	<b>CALIFORNIA GROWN BUNCH SPINACH</b> bunch 49¢
<b>CALIFORNIA GROWN PEPPERS</b> 84¢ kg	<b>WASHINGTON, CANADA NO. 1 TOMATOES</b> 1 <sup>72</sup> kg 78¢ lb.	<b>WASHINGTON, CANADA FANCY GRADE RED DELICIOUS APPLES</b> 1 <sup>08</sup> kg. 49¢ lb.	<b>CALIFORNIA GROWN PINK GRAPEFRUITS</b> 5 FOR 98¢
<b>WASHINGTON, CANADA NO. 1 GRADE RUSSET POTATOES</b> 10 lb. bag 43¢	<b>WASHINGTON, CANADA FANCY GRADE GOLDEN DELICIOUS APPLES</b> 1 <sup>08</sup> kg. 49¢ lb.		

## NIROZEN FOODS

**NIAGARA CONCENTRATE CITRUS BEVERAGE** 341 mL tin 79¢

AUNT JEMIMA | CARNATION

yielded no more, Discovery lived no more.

Tribute to that forgotten town may be found among the buildings of Atlin, where a number of homes and stores were brought and set up.

Why go to Atlin?

Some years ago the Government Agent at Duncan was Lyman Sands. After making various moves, from agency to agency, he was stationed at Atlin. Its remote

location and its struggle for survival were familiar to Sands. He was born in Atlin and it was like coming home.

We were all linked to Atlin by its former government official. For several years I was in the habit of having lunch with Sands on Wednesdays in Duncan. My old air force "oppo," George Jessup, worked with Sands as assessor and at one stage of his career Lyman was agent in Fort St. John, where

my brother, Laurence, has lived for a quarter of a century. And we all wanted to find what made him tick so far away from at least two of us.

Driving in from Skagway, in Alaska, you turn right at Jake's Corners and you drive about 75 kilometres along a largely dirt road before you reach a vast lake with a mountain rising from its waters. That's Atlin.

Having driven in on that road

you study the route because it's the only way out. It is the Atlin Road, for it leads to no other place.

There are no paved streets in the community, but it has never known such highways. Road repairs are strictly by grader. Winter snows are cleared by the same machine and summer dust is laid by water tanker.

A visitor might start by listing what Atlin doesn't offer. The list would be extensive, but a

community of some 500 people does not merit too big a list of amenities. After all, you can buy all the food you could need and most of what you might want. General stores are available and clothing is right there on the shelf. And if you need something that isn't stocked in the community, you tear up the dirt road as far as Whitehorse, which is the local big town.

Turn to Page B10

# Fairway's BEST BUY PRODUCTS

<p><b>SAUSAGE</b> 100 gram ..... <b>1.99</b></p> <p><b>ROAST BEEF</b> 100 gram ..... <b>85¢</b></p>	<p><b>Waffles</b> 1 kg bag ..... <b>1.88</b></p> <p><b>GREEN PEAS</b> 1 kg bag ..... <b>2.38</b></p> <p><b>KERNEL CORN</b> 1 kg bag ..... <b>2.38</b></p>	<p><b>SAUSAGE</b> 100 gram ..... <b>1.99</b></p> <p><b>ROAST BEEF</b> 100 gram ..... <b>85¢</b></p>	<p><b>Waffles</b> 1 kg bag ..... <b>1.88</b></p> <p><b>GREEN PEAS</b> 1 kg bag ..... <b>2.38</b></p> <p><b>KERNEL CORN</b> 1 kg bag ..... <b>2.38</b></p>
<p><b>POST "NEW" WITH CALIFORNIA RAISINS</b></p> <p><b>GOLDEN RAISIN BRAN</b> 525 gram box ..... <b>2.07</b></p> <p><b>RAISIN BRAN &amp; GRANOLA</b> 525 gram box ..... <b>2.07</b></p>	<p><b>POST MICKEY MOUSE MAGIC CRUNCH</b> 375 gram box ..... <b>2.28</b></p> <p><b>CEREAL</b> 375 gram box ..... <b>2.28</b></p>	<p><b>POST "NEW" WITH CALIFORNIA RAISINS</b></p> <p><b>GOLDEN RAISIN BRAN</b> 525 gram box ..... <b>2.07</b></p> <p><b>RAISIN BRAN &amp; GRANOLA</b> 525 gram box ..... <b>2.07</b></p>	<p><b>POST MICKEY MOUSE MAGIC CRUNCH</b> 375 gram box ..... <b>2.28</b></p> <p><b>CEREAL</b> 375 gram box ..... <b>2.28</b></p>
<p><b>QUARTER SQUARES</b></p> <p><b>KRAFT PARKAY MARGARINE</b> 3 -lb. pkg. .... <b>2.15</b></p>	<p><b>NESTLE ASSORTED MINI PUDDING</b> 4's 142 g pkg. .... <b>1.65</b></p> <p><b>PRODUCT OF AUST. ARDMONA FRUIT</b> 398 mL tin .. <b>88¢</b></p>	<p><b>QUARTER SQUARES</b></p> <p><b>KRAFT PARKAY MARGARINE</b> 3 -lb. pkg. .... <b>2.15</b></p>	<p><b>NESTLE ASSORTED MINI PUDDING</b> 4's 142 g pkg. .... <b>1.65</b></p> <p><b>PRODUCT OF AUST. ARDMONA FRUIT</b> 398 mL tin .. <b>88¢</b></p>
<p><b>SAFFLO SOFT MARGARINE</b> 2 -lb. tub ..... <b>1.99</b></p> <p><b>LIBERTY 100% PURE VEGETABLE OIL</b> 3 litre jug ..... <b>3.18</b></p>	<p><b>GOLDEN BOY REG. or CRUNCHY PEANUT BUTTER</b> 1.5 kg pail ..... <b>2.88</b></p>	<p><b>SAFFLO SOFT MARGARINE</b> 2 -lb. tub ..... <b>1.99</b></p> <p><b>LIBERTY 100% PURE VEGETABLE OIL</b> 3 litre jug ..... <b>3.18</b></p>	<p><b>GOLDEN BOY REG. or CRUNCHY PEANUT BUTTER</b> 1.5 kg pail ..... <b>2.88</b></p>
 <p>The Great Canadian Cheese Festival™</p>			
<p><b>MEDDO BELLE RANDOM CUT CHEESE</b> 25% OFF AT THE CHECK-OUT</p> <p><b>KRAFT CRACKER BARREL MILD CHEDDAR</b> 227 gram pkg. .... <b>1.78</b></p> <p><b>SCHNEIDER'S CHEESE SLICES</b> 500 gram 24's pkg. ... <b>2.78</b></p>	<p><b>ARMSTRONG RANDOM CUT CHEDDAR</b> 25% OFF AT THE CHECK-OUT</p> <p><b>KRAFT MEXICAN CHEEZ WHIZ</b> 500 gram jar ..... <b>2.97</b></p> <p><b>BLACK DIAMOND 100% PURE GRATED PARMESAN</b> 250 gram shaker ..... <b>2.98</b></p>	<p><b>MEDDO BELLE RANDOM CUT CHEESE</b> 25% OFF AT THE CHECK-OUT</p> <p><b>KRAFT CRACKER BARREL MILD CHEDDAR</b> 227 gram pkg. .... <b>1.78</b></p> <p><b>SCHNEIDER'S CHEESE SLICES</b> 500 gram 24's pkg. ... <b>2.78</b></p>	<p><b>ARMSTRONG RANDOM CUT CHEDDAR</b> 25% OFF AT THE CHECK-OUT</p> <p><b>KRAFT MEXICAN CHEEZ WHIZ</b> 500 gram jar ..... <b>2.97</b></p> <p><b>BLACK DIAMOND 100% PURE GRATED PARMESAN</b> 250 gram shaker ..... <b>2.98</b></p>
<p><b>PHILIP BUDGET LIGHT BULBS</b> 2's 40 Watts 60 Watts 100 Watts box ..... <b>78¢</b></p> <p><b>DR. BALLARD ASSORTED PREMIUM DOG FOOD</b> 18"x 25 ft. BOX ..... <b>1.98</b></p>	<p><b>REG. or CONDITIONING BONUS PACK HEAD &amp; SHOULDERS SHAMPOO</b> 550 mL btl. .... <b>4.48</b></p> <p><b>MINT or PEPPERMINT SCOPE MOUTHWASH</b> 750 mL btl. .... <b>3.88</b></p> <p><b>MISS MEW ASSORTED CAT FOOD</b> 170 gram tin ..... <b>32¢</b></p>	<p><b>PHILIP BUDGET LIGHT BULBS</b> 2's 40 Watts 60 Watts 100 Watts box ..... <b>78¢</b></p> <p><b>DR. BALLARD ASSORTED PREMIUM DOG FOOD</b> 18"x 25 ft. BOX ..... <b>1.98</b></p>	<p><b>REG. or CONDITIONING BONUS PACK HEAD &amp; SHOULDERS SHAMPOO</b> 550 mL btl. .... <b>4.48</b></p> <p><b>MINT or PEPPERMINT SCOPE MOUTHWASH</b> 750 mL btl. .... <b>3.88</b></p> <p><b>MISS MEW ASSORTED CAT FOOD</b> 170 gram tin ..... <b>32¢</b></p>
<p><b>A 100% COMPLETE AND BALANCED FORMULA FOR ADULT DOGS</b></p> <p><b>MAINSTAY DOG FOOD</b> 8 kg bag ..... <b>3.98</b></p>	<p><b>BUY BY THE CASE OF 4's, \$39.92</b></p> <p><b>HUGGIER ULTRA DIAPERS</b> All size pkg. Except Jumbo Pack ..... <b>9.98</b></p>	<p><b>A 100% COMPLETE AND BALANCED FORMULA FOR ADULT DOGS</b></p> <p><b>MAINSTAY DOG FOOD</b> 8 kg bag ..... <b>3.98</b></p>	<p><b>BUY BY THE CASE OF 4's, \$39.92</b></p> <p><b>HUGGIER ULTRA DIAPERS</b> All size pkg. Except Jumbo Pack ..... <b>9.98</b></p>
<p><b>FRANCO-AMERICAN IN TOMATO SAUCE SPAGHETTI or SPAGHETTI'S</b> 398 mL tin ..... <b>49¢</b></p>	<p><b>DELSEY BATHROOM TISSUE</b> 8 rolls ..... <b>2.68</b></p>	<p><b>FRANCO-AMERICAN IN TOMATO SAUCE SPAGHETTI or SPAGHETTI'S</b> 398 mL tin ..... <b>49¢</b></p>	<p><b>DELSEY BATHROOM TISSUE</b> 8 rolls ..... <b>2.68</b></p>

WE RESERVE THE RIGHT TO LIMIT QUANTITIES

# Insight into mining history found in Atlin

**From Page B9**

Then the visitor would have to start listing what Atlin does offer.

It offers the lake which gave the town its name. The native Tlingit Indians called it "Great Water" and the name has stayed.

Its main traffic until the end of the last century was that of the Tlingits hunting caribou. The change came with a party of prospectors, headed by Fritz Miller in 1899. Miller had already found gold in Pine Creek but had run out of supplies and returned to Juneau. He later told the Atlin *Claim* newspaper that he had taken \$120 in gold the first day he operated his sluice box.

The lake, today, offers fishing and boating. The country provides for hunting and the short summer will produce a wide range of crops. Incidentally, we found rhubarb growing everywhere. It's a weed!

Most interesting was a visit to the gold mines and to an insight into mining history. Where once a lone miner was digging a shaft down to the gold-bearing gravel, there are giant bulldozers working in teams to take off the overburden and reach the precious metal which has lain hidden for countless years. The golden gravel is loaded onto belly dumpers and hauled to the processing equipment at a central point.

We watched the great shovels moving a creek bed and we watched two of a dozen belly dumpers lumbering over the ground. It was a small mine but it employed a lot of people and a pile of equipment.

The most interesting from the standpoint of an onlooker was the "glory-hole" where machines had dug down to the gold. One side of the deep hole was almost vertical and in the wall could be seen the shaft of a mine dug nearly a century ago when gold was won only by the sweat of the brow.

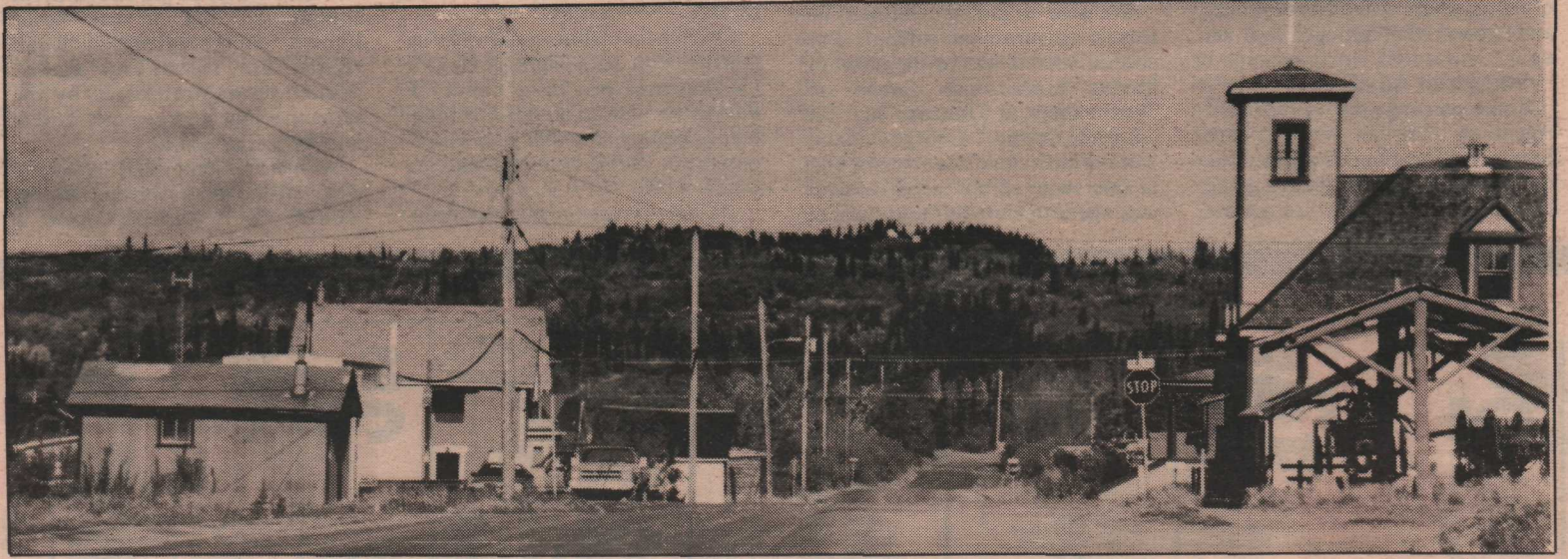

*Atlin retains historic flavour*

Never had that early miner imagined that one day his handiwork would lie open to the light of day.

I learned, in Atlin, the meaning of a "placer" mind. It is a Spanish term which has been lawfully anglicized by its use in the United States mining regulations. Placer gold is found in the form of metal. It is not dug as ore and requires no smelting. I expect every reader knew that, but I didn't.

A museum in Atlin preserves early pictures and records as well as a variety of tools and equipment from the quite recent past. The museum also displays a large range of ancient machinery salvaged from various mining operations. Unfortunately, there is little keen interest evident in renovating any of the old tractors and bulldozers, motors, steam shovels and the like.

I enjoyed Atlin and I could visit there again, but the long winters would scare me off. I'm too spoiled by creature comforts to hanker after cold winters again. Yet I can

see the attraction and even the challenge of a community that has seen its thousands of residents shrink to a hundred or so and is now once again on the rise.

Incidentally, we enjoyed a very pleasant stay in the former home of a successful miner. The Noland House was the home of a miner of that name. When he found gold he left home. The house has been modernized and brought into the 21st Century.

## Real Property Law

Offers to Purchase - Conveyances - Mortgages  
Subdivisions - Rights of Way - Foreclosures

TALK TO

**Jonathan L. Oldroyd**  
BARRISTER & SOLICITOR

121 McPhillips Ave., Ganges

537-2752

## CAPITAL REGIONAL DISTRICT NOTICE OF ELECTION

November 1988

### LOCAL TRUSTEES — ISLANDS TRUST TWO YEAR TERM — 1988-1990

Public Notice is hereby given to the electors of:

- Galiano Island Group
- Mayne Island Group
- North Pender Island Group
- Salt Spring Island Group
- Saturna Island Group
- South Pender Island Group

that I require the presence of the electors at the Capital Regional District offices, (3rd floor), 524 Yates Street, Victoria, B.C., on **MONDAY, the 31st DAY OF OCTOBER, 1988, at 10:00 am** to elect Local Trustees to the Islands Trust for:

Galiano Island .....	2 to be elected
Mayne Island .....	2 to be elected
North Pender Island .....	2 to be elected
Salt Spring Island .....	2 to be elected
Saturna Island .....	2 to be elected
South Pender Island .....	2 to be elected

The mode of nomination of candidates shall be as follows:

Candidates shall be nominated in writing by 2 qualified electors of the said island. The nomination paper shall be delivered to the Returning Officer at any time between the date of this notice and noon of the day of nomination. The nomination paper may be in the form prescribed in the Municipal Act, and shall state the name, residence and occupation of the person nominated in a manner sufficient to identify the candidate. The nomination paper shall be signed by the candidate.

In the event a poll is necessary, the poll will be opened on **SATURDAY, the 19th DAY OF NOVEMBER, 1988, between the hours of 8:00 am and 8:00 pm** at the following locations:

<b>GALIANO ISLAND</b>	Galiano Elementary School
<b>MAYNE ISLAND</b>	Mayne Elem./Jr. Sec. School
<b>NORTH PENDER ISLAND</b>	Pender Island School, Canal Road
<b>SALT SPRING ISLAND</b>	Salt Spring Elementary School Central Community Hall Fulford Harbour Community Hall
<b>SATURNA ISLAND</b>	Saturna Island Community Hall
<b>SOUTH PENDER ISLAND</b>	Pender Island School, Canal Road

An Advanced Poll will be held on **MONDAY, 14th NOVEMBER, TUESDAY, 15th NOVEMBER** and **WEDNESDAY, 16th NOVEMBER, 1988, between the hours of 8:30 am and 4:30 pm** at the following locations:

- School District No. 64 Board offices, Lower Ganges Road, Ganges, B.C.
- Capital Regional District offices, 524 Yates Street, Victoria, B.C.

of which every person is hereby required to take notice and govern himself accordingly.

Dated at Victoria, British Columbia, this 6th day of October, 1988.

**THOMAS F. MOORE**  
Returning Officer

## NOTICE

### Salt Spring Island Trust Committee TUP - 3 - 88

NOTICE is hereby given that the Salt Spring Island Trust Committee will consider the issuance of a Temporary Commercial and Industrial Use Permit pursuant to Section 975 of the *Municipal Act*, R.S.B.C., 1979, to allow for Retail Sales of new and used automobiles and an office and sales building not exceeding 37 square metres (400 square feet) on Lot 5, Plan 5827, Section 1, Range 3 East, North Salt Spring Island, Cowichan District. The location of the subject land is shown on the following sketch:

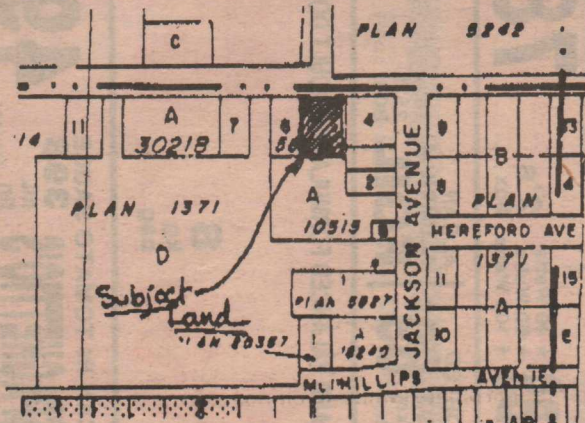

A copy of the proposed permit may be inspected at the Islands Trust Office, 747 Fort Street, Victoria, B.C. between the hours of 8:30 am to 4:30 pm, Monday to Friday inclusive excluding statutory holidays. The Salt Spring Island Trust Committee will meet at the Harbour House Hotel in Ganges, B.C. on Friday, October 21, 1988 at 1:30 pm to consider a resolution to adopt the proposed permit.

**CYNTHIA HAWKSWORTH**  
Manager



Jim Beck and Eddie Waddel help sort through contents of box of clothing donated to the Community Clothing and Craft Store.

## Fund-raising benefits Achievement Centre

### From Page B1

selected to be displayed in the store," McEacher said.

The Clothing and Craft Store is another training outlet. Operated by a full-time employee of the centre, assisted by some of the handicapped people, it provides, in many cases, a first-time exposure to life in the community.

"They gain a measure of self-confidence to a point where a few of them go to a nearby restaurant for coffee break by themselves," Doucet said. "It may seem a small thing but it is something they never would have been capable of doing before they became participants in the Activity Centre programs.

Doucet is concerned about the future of the store. "It is not yet self-supporting and is still being subsidized by the Community Society," she said. "If things don't improve we are going to have to look pretty closely at its operation. We can't afford a continuous subsidy for it."

In addition to the various training programs it conducts, the Activity Centre provides a number of recreational activities such as bowling, swimming, an exercise program, some camping and special outings. There are also music and theatre classes on a weekly basis.

Much of the financing for the operation of the Activity Centre comes through the provincial ministry of social services and housing, the local parks and

recreation commission (which finances the bowling program), from the sales of services and goods produced by the participants, and by many private donations.

"However, there is always a need for more funding," Doucet said. "We are hopeful that some of it will come from the grants the Community Centre will receive through its participation in the United Way of Greater Victoria."

This will be the second year residents of Salt Spring have been given the opportunity to contribute to the United Way and, through it, support the widespread community services provided by the Community Society. This year's solicitation will be in the form of an insert in the October 12 issue of *Driftwood*. In addition, personal letters will be mailed to 1,100 residents of the island.

### Club prize won

The Salt Spring Island 4-H Club has announced the winner of the Fall Fair draw for its quilt: Johana McLaughlin.

The club congratulated McLaughlin on her win, and thanks the Farmers' Institute for staging the fair.

Meanwhile, the club notes that its banquet is scheduled for October 14 at 6:30 pm in the Fulford Community Hall.

DON'T LET WILDFIRES BE



For Complete Moving Services  
Local or Long Distance

Call  
**McCully Moving Ltd.**  
537-5491

### ISLAND WELL DRILLING LTD.

Red Williams, owner-operator

AIR ROTARY EQUIPMENT

Serving the Gulf Islands since 1959 Call collect 245-2078

## ISLANDS TRUST Galiano Island Trust Committee NOTICE OF PUBLIC HEARING

NOTICE is hereby given that all persons who deem their interest in property affected by the following proposed bylaws will be afforded an opportunity to be heard on the matters contained therein at a Public Hearing to be held **AT THE SOUTH END COMMUNITY HALL, STURDIES BAY ROAD, GALIANO ISLAND, B.C.** on **THURSDAY, OCTOBER 20, 1988, COMMENCING AT 12:30 P.M.**

In general terms:

- Proposed Galiano Island Trust Committee Bylaw No. 65, cited as "Zoning Bylaw, Galiano Island and Area, 1978, Amendment Bylaw No. 4, 1988" is a bylaw to amend the Galiano Island Zoning Bylaw, cited as "Zoning Bylaw, Galiano Island and Area, 1978" by deleting from the Agricultural (AG) Zone and adding to the Commercial 2 (C2) Zone and to the Rural 1 (R1) Zone that portion of Parcel "A", (DD40067-1) of Lot 3, Galiano Island, Cowichan District, except Plans 7259, 13005, 25129, 27829 and 34507, as shown generally in the following sketch, subject to the conditions that:

- Uses permitted on the land zoned Commercial 2 (C2) shall be limited to:
  - A country inn having a maximum floor area of not more than 8.7 per cent of the land zoned Commercial 2 (C2), of which not more than 5500 square feet (511 m<sup>2</sup>) shall be used for overnight accommodation of the transient public;
  - A restaurant;
  - Retail uses accessory to the above uses, limited to a floor area of not more than 300 square feet (28 m<sup>2</sup>);
  - One self-contained dwelling unit for the accommodation of the owner, operator, or employee of the uses permitted above; such dwelling unit shall have a minimum floor area of 400 square feet (37 m<sup>2</sup>).
- With the exception of permitted use 1.(d) above, all uses permitted under Condition 1, above, shall be conducted within a building having a common main entrance and a maximum height not exceeding 30 feet (9.1 m).
- A restrictive covenant applicable to the land being rezoned to Commercial 2 (C2) by this bylaw shall be placed upon the title of Parcel "A" (DD40067-1) of Lot 3, Cowichan District, Galiano Island, except Plans 7259, 13005, 25129, 27829 and 34507, under Section 215 of the *Land Title Act*, R.S.B.C. to the effect that:
  - Subdivision of Commercial 2 (C2) zoned land is prohibited;
  - Any liquor licence obtained for buildings upon the land shall be limited to a category "B" Dining Lounge licence.

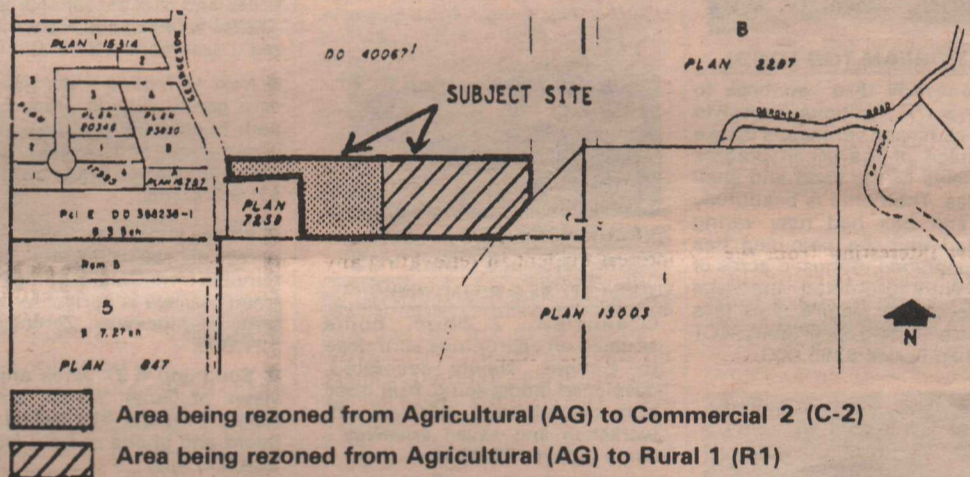

- Proposed Galiano Island Trust Committee Bylaw No. 62, cited as "Official Community Plan (Galiano Island and Area) Bylaw, 1973, Amendment Bylaw No. 1, 1988" is a bylaw to amend the Galiano Island Official Community Plan Bylaw, cited as "Official Community Plan (Galiano Island and Area) Bylaw, 1973" by altering the Plan Map, Schedule "A", to delete from the Rural 2 and 3 Land Use category and add to the Rural 1 Land Use category that portion of Lot 1 of Lot 83, Galiano Island, Cowichan District, Plan 20871, except that part thereof included within the boundaries of Plan 23513, the location of which is shown generally in the underlying sketch.

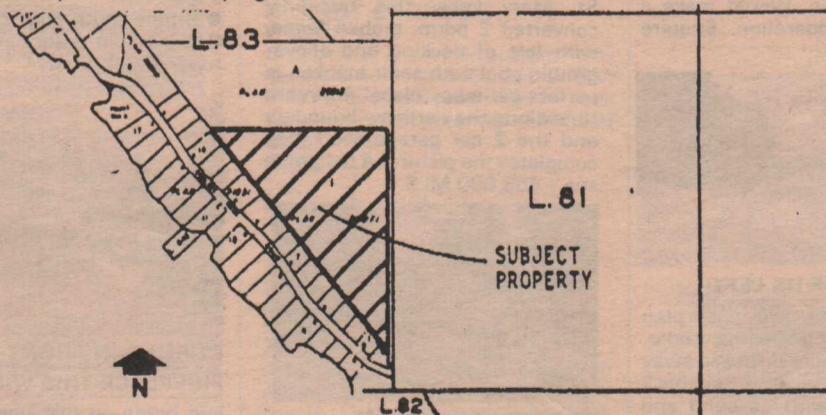

- Proposed Galiano Island Trust Committee Bylaw No. 63, cited as "Zoning Bylaw, Galiano Island and Area, 1978, Amendment Bylaw No. 2, 1988" is a bylaw to amend the Galiano Island Zoning Bylaw, cited as "Zoning Bylaw, Galiano Island and Area, 1978" by deleting from the Rural 2 (R2) Zone and adding to the Rural (R1) Zone that portion of Lot 1 of Lot 83, Galiano Island, Cowichan District, Plan 20871, except that part thereof included within the boundaries of Plan 23513, the location of which is shown generally in the sketch referred to in Section 2 of this Notice. As a condition, the landowners agree to register a restrictive covenant applicable to the land being rezoned by this bylaw, upon the title of the aforementioned Lot 1 limiting the number of single family dwellings to a maximum of three (3) and excluding any permitted guest accommodations referred to in Section 8.2 of the Galiano Island Zoning Bylaw.

A copy of the proposed bylaws may be inspected at the Islands Trust office, 747 Fort Street, Victoria, B.C. between the hours of 8:30 am to 4:30 pm, Monday to Friday inclusive, excluding statutory holidays.

For the convenience of the public only, and not to satisfy Section 957(2)(v) of the *Municipal Act*, additional copies of the proposed bylaws may be inspected at the Post Office Lobby, Galiano Island.

**CYNTHIA HAWKSWORTH**  
Manager



# PEMBERTON, HOLMES LTD.

## 537-5568

P.O. Box 929, Ganges, B.C.  
156 Fulford-Ganges Road

Victoria Direct Line 652-9225 Fax 652-9225

1887 - 1988 — 101 years as your good neighbour! — 1887 - 1988

### BE COMFORTABLE IN THIS COSY HOME BEFORE WINTER WINDS HOWL

Almost 6 acres of privacy and seclusion located midway between Ganges and Fulford. A delightful 2 bdrm. home with wainscotting and beamed ceiling. Also has a view site including pond and seasonal stream. Driveway to back of property. Lots of potential for the future, great for just now! \$79,900 MLS.

### I'M BACK ON THE MARKET!

Oceanview income property currently divided into 2 rental suites. Close to town yet private and quiet. Excellent holding property. Value like this sells fast. \$77,900 MLS.



### DON'T DREAM TOO LONG!

This one will take you back to yesteryear. A traditional farm style home with open verandahs to take advantage of the ocean breezes and views of the sand and shell beaches. The home is beautifully built and has had new wiring installed and the plumbing has been upgraded. Almost 6 acres of land with protected moorage completes the picture. This is a once in a lifetime opportunity. ACT NOW! Full price \$395,000.



### YOUR CHOICE!

Local hardware store for \$69,000 or rental business for \$40,000. Excellent business with a secure long term lease. Would make a super family operation. Enquire today.



### NOT MANY OF US LEFT!

Waterfront home with open plan living and dining. Beams, cedar, skylights and more is tucked away on a secluded dead end. See this 2 bdrm. beauty with its sand and shell beach! \$175,000 mls.



### YEAR 'ROUND VACATION HOME YOU WON'T WANT TO LEAVE!

Creative placing of windows allows all day sunshine in this year 'round vacation home. Nestled in the woods this 2 bdrm. wood home is just minutes from swimming, boating and fishing on St. Mary Lake. \$71,900 mls.



### BEST BUY!

Country home on 5 acres has attractive woodwork and finishing throughout. Pond and good arable area. Price reduction puts it below reproduction cost. Don't be a slow poke! \$112,900. \$107,900 mls.



### DO YOU HAVE A HORSE?

Then this is the place for you! This 3 bdrm. log home is finished in traditional style and sits on 1 1/2 secluded acres with a fenced pasture. Open plan living and family style kitchen with wood cookstove. \$89,900 mls.



### VALUE-PACKED, COMFORTABLE HOME YOU SHOULD SEE RIGHT NOW!

Oceanview, 2 bdrm. home situated on approx. one acre close to Ganges. Newly decorated, developed landscaping, fruit trees and greenhouse. 400 sq. ft. workshop and paved driveway - see it today! \$85,000 mls.



### FISH, HIKE & RELAX

Close to Vesuvius, minutes from St. Mary Lake, this tastefully converted 2 bdrm. mobile home, with lots of decking and above-ground pool with solar blanket, is perfect get-away place! A stream runs along the northern boundary and the 2 car garage/workshop completes the picture! A delight to see - \$53,900 MLS.



### ARE YOU AN ARTIST?

Private 1.46 acres has frontage on 2 roads. This character 2 bdrm. home just steps to St. Mary Lake has separate studio and garage to suit the artist. Nicely wooded with mature trees. Piped water, hydro and apples on the tree. See it today! \$82,500 MLS.



### STRATEGICALLY LOCATED COMMERCIAL 1 ZONED PROPERTY

On McPhillips Ave., lot size 66' x 198'. Almost 1478 sq. ft. of space with 908 sq. ft. on main. Close to Ganges bypass. Adequate space at side of lot will provide access to rear of lot for parking. Existing buildings can easily be expanded to provide for most leasable space. \$129,000 mls.

### DON'T MISS THIS OPPORTUNITY TO OWN EXCEPTIONAL PROPERTY EASILY

- Fantastic view acreage, Mt. Baker, Outer Islands and sea. Creek and park at rear of property. Access to beach and waterfront by reg'd easement. \$59,900 mls.

- Next to Sailing Club, this 1.08 acre gently sloping property has path to ocean. Fruit trees, superb ocean view and deep moorage. Hydro and piped water available. \$109,500 mls.

- All day sun! Great value. Over 5 acres of seclusion and just 5 minutes from Ganges village. Well treed acreage is perfect for hobby farm or hideaway. Zoning RR1. \$21,900.

- Southend 4.97 acres enjoying views of Outer Islands and Mt. Baker. Property has drilled well, hydro and phone at front lot line. \$59,000 mls.

- Acreage with lots of sun and timber! This 3-plus acres has view potential and is easily accessible from road. Close to town and ferries. \$28,500 mls.

- 10 acres with creek frontage close to Blackburn and Cusheon Lakes. Ideal swimming and fishing. Hydro on the road, ready to go. \$55,000 mls.

- Sunny south end 5 level acres. Good arable potential. Hydro on road. \$37,900 mls.



### CURL UP IN FRONT OF YOUR FIREPLACE THIS WINTER!

Log home on just under 2 acres with well-built log home. Nicely finished with 4 bdrms and a lower frame level with recreation room. Close to ocean and town and has a separate studio/workshop. \$77,900 MLS.

KERRY & ARVID CHALMERS  
537-5568 or 537-2182

### INVESTMENT OPPORTUNITIES

- In commercial core of Ganges. Currently zoned residential but in location easily rezoned to Commercial 1. \$45,000 MLS.
- Ocean view building lot with cleared building site. Sunny, quiet,

- almost 5 acres. Close to St. Mary Lake for swimming, fishing and boating. Driveway and hydro to house site are in place. All the hard work is done. \$49,000 mls.

For more information, or to visit these specials, speak to:

WYNNE DAVIES  
537-5568 or 537-9484

### 60 ACRE FARM & LOG HOME

You will discover a world apart on this carefully developed island property. Approximately half in cropland and pasture and half in managed forest, all work has been done with an eye to beauty and to a long tenure on the land. Included are a log barn, guest cabin, many outbuildings and much fencing, a complete road system, 3 ponds, a creek, some farm machinery and a small herd of cattle. \$425,000 mls.

Also available in two parcels:

- House and all improvements on 27+ acres for \$260,000

- 33+ acres with growing land, forest, ponds, creek and fencing for \$100,000



### PICTURE PERFECT

The photo speaks for itself! Imagine yourself curled up in front of the fire in this cosy little home - so near to town yet very private, 2 bedrooms up. Carport and potting shed. Just listed at \$77,500 mls.

### CHARACTER PLUS

This 3 bdrm. home (2 up, 1 down) has many rustic features, leaded glass, etc. on 1 1/2 acres south sloping land. Wood or electric heat. Garden area. Just a few moments walk to one of the best swimming/clamming beaches on the island. \$89,000.

### SCARCE SOUTH-FACING WATERFRONT

Approx. 175 ft. accessible waterfront on 1.42 acres. Spectacular building site reached from Margaret Drive (watch for signs). Septic field in and approved for 3 bdrm. home. This won't last! \$125,000.

ANN FOERSTER  
537-5568 or 537-5156



### BIRD HOUSE BED & BREAKFAST

This country home and cabin (Birdhouse) are set on 3.72 acres of pastoral fields and very nicely landscaped gardens. Seasonal creek and pond. Located in sunny, private area at the north end of the Island. \$115,000 MLS.



### GREAT FAMILY HOME

Spacious 4 BR. home in good area for children. 2500 sq. ft. of finished living space. 1/2 acre of nicely landscaped level property. Very efficient heatilator fireplace. Good ocean views. Reduced to \$92,500.

### SOMETIMES —

We offer for sale a property which does not get the buyer attention it deserves. We are convinced that ALDERCROFT FARM is just such a property and that it has in fact, for some unaccountable reason, been overlooked. Here are some of the features that make this very desirable property worth your attention.

- over 50 acres of subdividable land
- South west facing view property
- 15 acres of fenced pasture
- large and well built barn
- good soil
- seasonal creek and pond
- high producing well
- 4 bdrm. cottage with large sundeck

For comparable investment or farm property at anywhere near this price you will have to look somewhere else than Salt Spring Island. Give yourself a treat if this is your kind of property, and in your price range - call me and I will be pleased to show it to you. \$265,000 mls.

DAVID WILLIAMS  
537-5568 or 537-9510 or  
384-0230

SELF-SUFFICIENCY - is possible on this 17 acre family farm. Good fenced pastures and the finest market garden have made this farm arable for more than 100 years. There is also a new pig barn and the largest fish pond you ever saw, and of course, a comfortable farmhouse. Realistically priced at \$145,000 mls.

DREAM PROPERTY - If someone told you that such a property exists just 2 miles out of GANGES: that this property, due to its size of 10+ acres affords secluded, peaceful privacy; that it is fully serviced and, most importantly, provides stunning southwestern ocean views - wouldn't you run out and see for yourself? You would then discover another pleasant surprise: a warm beach in walking distance! At just \$85,000 you simply can't afford to miss this rare gem. Let's check it out today!

WILF BANGERT  
537-5568 or 537-5692

### PANORAMIC VIEW ACREAGE

Superb views of Mt. Baker, San Juan Islands, Gulf Islands. Very sunny exposure on this 12+ acres. Power, telephone, building site and driveway. \$69,500 mls.



### DON'T MISS THIS BUY!

This unique home is nestled on a sunny, sloping .94 acre in a peaceful area. It features stained glass windows, kitchen cabinets with leaded glass doors, outdoor sprinkling system. Very efficient attached greenhouse. Carefully placed windows allow all day sun. \$69,000.

### MOST FOR THE MONEY

1/2 acre of level nicely treed property. Good sunny area. Only 2 min. short walk to beaches. \$15,500.

FOR FURTHER INFORMATION  
CALL FINN RONNE  
537-5568 or 537-4072

1101  
GRACE POINT  
SQUARE  
P.O. Box 454  
Ganges, B.C.  
V0S 1E0

**537-9981**

FAX #537-9551

# Century 21

ISLANDS REALTY LTD.  
**WE SET THE STANDARD**

**THE LARGEST  
REAL ESTATE  
ORGANIZATION  
IN THE WORLD**  
EACH OFFICE IS  
INDEPENDENTLY  
OWNED AND  
OPERATED

\* and \* Trademarks of  
Century 21 Real Estate Corporation



<b>ARTHUR GALE</b> Sales Rep. 537-5618	<b>SYLVIA GALE</b> Sales Rep. 537-5618	<b>ED DAVIS</b> Sales Rep. 537-2626	<b>EILEEN LARSEN</b> Sales Rep. 537-5067	<b>BECKY LEGG</b> Sales Rep. 537-5870	<b>BRIAN BETTS</b> Sales Rep. 537-5876	<b>JANET MARSHALL</b> Sales Rep. 537-5359	<b>PAT JACQUEST</b> Sales Rep. 537-5650	<b>GARY GREICO</b> Sales Rep. 537-2086	<b>DARLENE O'DONNELL</b> Sales Rep. 653-4386	<b>WARREN GARNER</b> Sales Rep. 537-2564	<b>ANNE WATSON</b> Sales Rep. 537-2284	<b>NEVILLE ATKINSON</b> Sales Rep. 537-2591	<b>TOM HOOVER</b> Principal Agent 537-5918
--	--	---	--	---	--	---	---	--	--	--	--	---	--

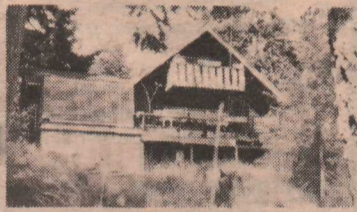

**SALT SPRING OCEANFRONT**  
3 BR West Coast Cedar post & beam home on beautiful Scott Pt. East facing house with potential for year-round protected moorage. Close to ferry. Rare Scott Point opportunity. \$194,500 MLS. CALL ED



**RARE OPPORTUNITY**  
This 39.86 acre parcel in the Fulford Valley offers a unique environment of rural living for the hobby or gentleman farmer. \$180,000. CALL EILEEN



**ST. MARY LAKEFRONT — ST. MARY LAKEFRONT — OWNER MUST SELL**  
Breakfast on the shore of tranquil St. Mary Lake. A vacation atmosphere year round. Move right in to this large south facing, 3 bdrm. home. Artist's studio could be a self-contained in-law suite or bed & breakfast. \$146,000 MLS. CALL GARY



**WALK TO GANGES**  
Close proximity to public beach access and Ganges makes this a very desirable area. This 4 bdrm., 1 1/2 bathrm. home is situated on a .73 acre sunny corner lot on dead-end street. In-law suite potential. List price \$97,500. CALL BECKY



**ACREAGE IN FULFORD VALLEY**  
Very nice 30 acre parcel in the lovely Fulford Valley. This property is one of a kind with large pasture area and a picturesque old barn. The remainder is gently sloping and well treed. \$180,000 MLS. CALL DARLENE

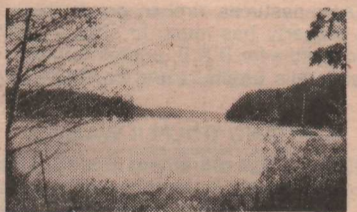

**LONG HARBOUR WATERFRONT**  
Beautiful 2.64 acres at the head of Long Hbr. with walk-on beach and year-round protected moorage. \$129,000 MLS. CALL SYLVIA OR ARTHUR



**JUST LISTED**  
2 BR. home on 0.65 acre, close to village, possible seaview, needs some TLC. Good revenue potential, cable TV., 2 wells. Listed at \$59,900 MLS. CALL JANET



**INVESTMENT OPPORTUNITY KNOCKING!**  
2 Rare C1 lots in Vesuvius Village with excellent rental revenue from 4-plex, and 2 shops. Call for details. \$175,000 MLS. CALL PAT

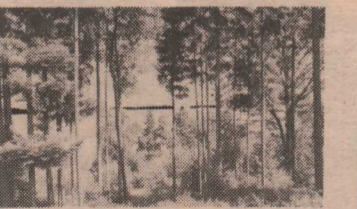

**SUNNY WESTERN EXPOSURE**  
Great opportunity for those looking for good value, over 2,000 sq. ft., ocean view, paved driveway. Walk to a great beach from here and enjoy warm swimming. Offered at \$87,000 MLS. CALL BRIAN



**GALIANO ISLAND**  
Farm acreage just minutes from Sturdies Bay ferry. 108 acres. Older home with cabin and garage. Approx. 83 acres farm zoned. 25 acres rural zoning. Potential for some subdivision, possible seaviews. \$280,000 MLS. CALL ED

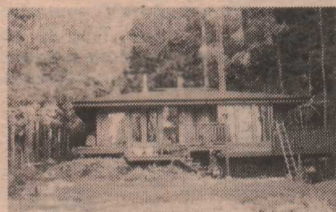

**SOUTHERN VIEWS**  
This brand new 2 bdrm. contemporary home offers vaulted ceilings, hardwood floors, skylights, walkaround decking and a seasonal creek in a very peaceful setting. \$86,900. CALL EILEEN

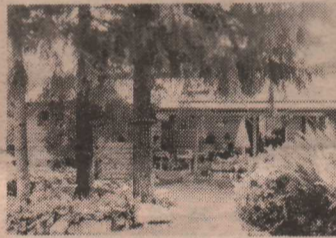

**"PARKLIKE BEAUTY"**  
3 bdrm., solid rancher. Brick hearth and Fisher stove in living room. Separate dining area with sliding glass doors leads to a covered patio and immaculate parklike garden. 0.54 acre totally landscaped and fenced. This gem will sell quickly. Please call me today for your private showing. \$91,000 MLS. CALL GARY



**PARK SETTING**  
Peaceful parklike setting with seasonal creek. This 2 bdrm. home is located close to town in quiet and peaceful setting. Very quaint and unique. Asking \$83,000 mls. CALL BECKY



**ARABLE ACREAGE CLOSE TO TOWN**  
There are 2 parcels of land making up this private 8.72 acres. Fenced for animals, lean-to & pond potential. A must see for the would-be farmer. \$75,000 MLS. CALL JANET

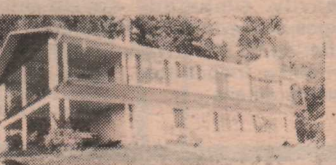

**MOUNT BAKER AND MORE**  
This 2500 sq. ft. 2 level home with 3 bdrms., hardwood floors, wrap around decking and a view that is second to none. Asking \$134,000 MLS. CALL EILEEN



**LOVELY VESUVIUS OCEANFRONT**  
Southfacing acre with superb views down Sansum Narrows and enjoying world class sunsets. Water system, hydro, cable. \$125,000 MLS. CALL SYLVIA OR ARTHUR



**SKY VALLEY RD. SECLUSION**  
Lovely 2 BR. home with lots of potential. Fenced garden areas, outdoor sauna, woodshed, garage & workshop. All day sun bathes this 3.36 acre property. Asking \$139,000 MLS. CALL JANET



**IT'S NOT ORDINARY — IT'S UNIQUE**  
It's all here! A 2 yr. old custom home set on 5 acres of secluded OCEAN VIEW property. Great hobby farm, or bed & breakfast potential. \$149,500 MLS. CALL PAT



**OVERLOOKING ST. MARY LAKE**  
Just under 10 acres with a truly superb view overlooking the lake. Tremendous potential to develop a private estate in a sunny quiet location. All trees blocking the view are on this property. The picture is from the next lot. Well priced at \$55,000 MLS. CALL BRIAN



**BUSINESS OPPORTUNITY**  
Established Mobile Home Park in good location mid-way between Fulford Harbour & Ganges. 23 occupied pads, 3 RV sites plus residence home/office, bachelor suite & laundry. TURN-KEY operation, good cash flow. To view, CALL ED



**FANTASTIC VIEW — EXCELLENT REVENUE**  
\* View over Ganges Harbour  
\* In-law suite  
\* Garden, strawberry beds, fruit trees  
Come view this large home with its high ceilings, separate dining area, large living room and a cosy glassed-in sunroom. The home requires some work, but is priced accordingly and some lucky handy person will reap the benefits of their efforts. CALL GARY



**JUST LISTED**  
Duplex on Epron Rd., 3 BR., 1 bathroom and basement per side. Located on 1.24 level acres. A history of revenue and good future investment potential. List price \$79,900 MLS. CALL BECKY

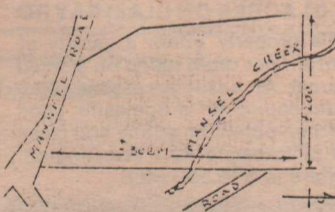

**WOODED 10 ACRES**  
Conveniently located on Mansell Rd. New public road permits access to quiet, sunny building site facing south over stream. About 3 ac. arable bottom land. Subdivision potential. Asking \$59,900 MLS. CALL SYLVIA OR ARTHUR



**CABIN ON OCEANVIEW ACREAGE**  
Live in this quaint, cosy cottage with hydro, telephone, cable TV & back to nature plumbing while you build your dream home on sunny 5 acres with lovely views of Ganges Harbour, the islands and snow peaked N. Shore mountains. CALL DARLENE

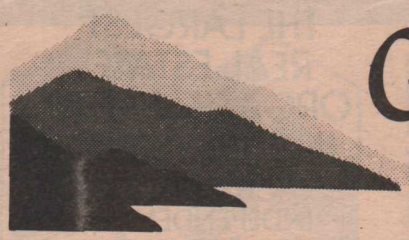

# GULF ISLANDS REALTY LTD.

P.O. Box 750, Ganges, B.C. V0S 1E0 — PHONE (604) 537-5577

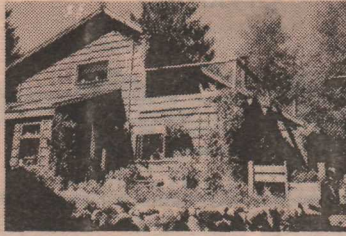

### RARE FULFORD HARBOUR BUILDING LOT

Almost 1 acre of treed property with several rocky outcroppings giving views over Fulford Harbour and of Mt. Bruce and Maxwell — the sunset view will be spectacular! This property in Reginald Hill has close access to small private beach and 74 acres of common property which includes a magnificent hilltop viewpoint and a large sheltered beach. Price? Just \$38,000 mls.



### TWILIGHT ISLAND

The pure white shell beaches of this jewel-like island are less than 2 miles from the docks on Saltspring. There's a two year old, 880 sq. ft. cabin, a separate sauna building, a flushing outhouse plus a propane toilet inside, huge sundecks on both sides of the cabin and a new deep water dock. Clams, crabs and fish are literally "at your doorstep." There's a propane stove, fridge and lights, plus a 110 volt light plant. All major furniture and the generator is included in the price of \$165,000 MLS.

DAVID DUKE  
653-4538

### DELIGHTFUL LAKESIDE FAMILY HOME

West coast contemporary on the outside with a warm old world charm on the inside. This spacious 2375 sq. ft. home offers many possibilities and opportunities: self-contained suite for visitors or as a B & B unit. There are 2 BR. & den or 3 BRs with a sundeck off the master; a separate bay windowed, wainscotted dining room, vaulted ceiling living room, efficient kitchen with huge pass-thru counter to a sun-filled skylite family room. Every room in the home is spacious and most have a peaceful lakeview. There's a workshop on the .84 ac. parcel and there's been extensive rock terracing and landscaping done. A pathway leads down to the lakeshore where there's a substantial float and diving board. This is real value at \$133,000 and the owners have bought "off island" and are motivated! MLS.

### MANOR HOUSE BY SEA & FIELD

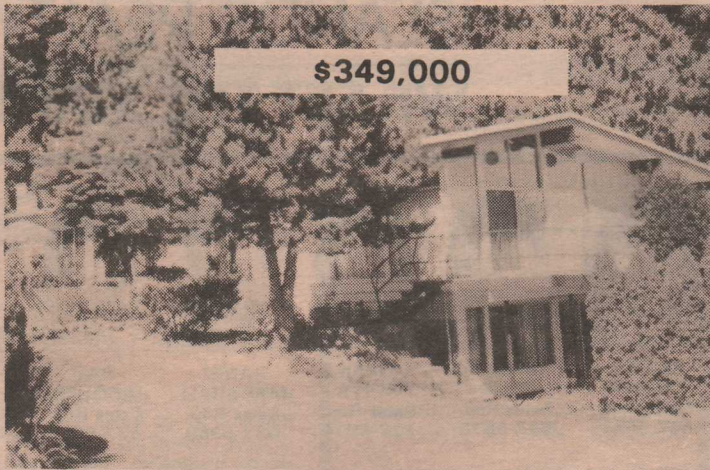

\$349,000

Features: Approx. 1000' waterfrontage; pastures; timber, pond, creek, guest cottage; views. This 22 acre property has much to offer — the comfortable and spacious home is adaptable for B & B, a large family or for entertaining off-island visitors! For details, brochure and viewing, call: JAN.

### SUNRISE COTTAGE



### HAVE YOU EVER DREAMED ATOP A MOUNTAIN?

Enjoy Eagle's territory - 10 acres of Salt Spring's FINEST VIEWS. Bonus - 600 sq. ft. guest cottage. Choice of bldg. sites for your DREAM HOME - \$85,000.

6 LOTS FOR \$33,000 OR  
2 TITLES FOR \$16,500 EACH  
\* CHEAP \* CHEAP \* CHEAP

Each lot is .25 ac. Purchaser to provide own water & septic field.

For free catalogue, call JAN MACPHERSON 537-9894

### GALIANO GOLFER WANTED

To build a retirement home on this delightful level 1/2 acre overlooking the green. The private house site is nestled among large cedars. Very pretty. Tee-off from your back yard! \$21,000.

### FERNWOOD FARM ACREAGE

2.7 sunny, level, arable acres, includes woodlot. Short walk to school, ocean and store. Perc tested. \$34,900.

### SATURNA ISLAND:

#### WATERFRONT - \$39,500?

Yes, believe it! Parklike, due south exposure and sunny and level. One of the few inexpensive waterfront properties available. View whales, freighters, marine activity from this lovely setting. (NOTE 1987 PRICE!)

### NOW - SERENITY - AT A NEW LOW PRICE - \$73,500 \$69,500



Peaceful sunny 1.97 acres with pleasant cedar cottage in the woods midway between Ganges and Fulford plus a 240 sq. ft. cottage/studio, small orchard, mature trees.

### NEW - WALK TO LONG HARBOUR FERRY

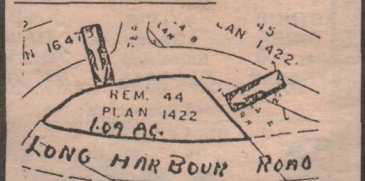

This 1.09 acre lot is cleared, with several good access areas, ideal for recreation purposes with water view building site. Vendor to drill well. \$24,900 MLS.

### THINKING SOLAR?



JUST LISTED - 1.28 ac. south facing lot, building site cleared, views of mountains and valley on community water system. \$23,900 MLS.

### WATERFRONT PROPERTIES DISTINCTIVELY MARACAIBO



Oceanfront home with all the features you would dream about. Deluxe kitchen, fantastic master ensuite, superb jacuzzi and patio, well finished with professionally landscaped garden, auto. watering system, dock and more. Now \$299,000 MLS.

### SUNSET DRIVE WATERFRONT HOME - \$425,000



Over 2700 sq. ft. with room to expand, located on 4.2 ac. with 110' of lowbank oceanfront, in-ground pool fully equipped. Home has 3 - 4 BR., large 26 x 18 living rm. and 19 x 14 dining rm., both with own fireplace, master suite - 19 x 14 BR., 15 x 10 bathroom and 12 x 8 dressing rm. Many other features including landscaping.

### SECLUDED ACREAGE YET CONVENIENT

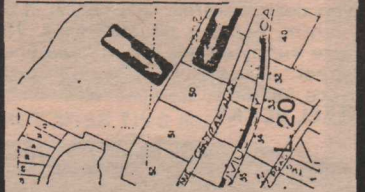

This near 5 ac. parcel located on little used Central Ave. off Quebec Dr. offers seclusion plus lots of cedar, possible pond, plus lots of sun. \$42,000 MLS.

CALL SANTY G. FUOCO  
537-2773

### JUST GIVE ME LAND!

In a quiet area of Salt Spring - approx. 5 acres of varied terrain, from rocky knolls for sunbathing to good soil for gardening. Sleeping cabin allows you to enjoy this property 'till you build. All this and highbank waterfront too. Best moorage on Salt Spring is just 1/2 block away. Asking \$74,900 MLS.



### YOU CAN'T JUDGE A BOOK BY ITS COVER! THIS IS A WELL CONSTRUCTED 2 BDRM. HOME ON 5 ACRES

This home offers the best of both worlds. It is situated on 5 unspoiled acres, is low maintenance and energy efficient. Skylights, cedar and a bathtub designed for luxuriating in make this an ideal spot for holidaying or retreat. Asking \$85,500 MLS.

CALL HENRI PROCTER FOR DETAILS  
537-5577 (o) or 537-4273 (h)

### PENDER ISLAND

#### 3.01 ACRES ON CLAM BAY RD

This property offers a variety of terrain not often found on a small parcel. An easily accessible rocky outcropping for a homesite, good garden potential, sunny and close to picturesque Port Washington. Offers to \$36,500 MLS.

### A HOBBY FARM ON 5 ACRES



This well cared for 1200 sq. ft., three bdrm. home features an outstanding fireplace, a huge deck and thermo-paned windows. Outside you will find a solid barn and woodshed and a large garden area with a sprinkler system. The property has been fenced and cross-fenced and the well has a flow that is far above average. \$120,000.

FRANCES EIDE — 537-5577 (o) or 537-9350 (h)



### STARTER/RETIREMENT RANCHER

One level living close to town. Some oceanview. Thermo windows. Woodstove, stove, fridge, drapes. On an easy care 1/2 acre serviced lot with piped water. \$71,500 MLS.



### AFFORDABLE OCEANVIEW CHARACTER HOME

Large bright rooms, 2 bdrms. and den up, possibly 2 bdrms. down. Brick fireplace, hardwood in liv. rm. \$67,500 - reduced to \$64,900 MLS.

15.9 ACRES  
\$53,500 MLS.

Your very own retreat - a magnificent 15.9 ac. parcel, heavily timbered, southern exposure towards Blackburn Lake. Offering TOTAL privacy. Trailer on property negotiable. Call for further details.



### LARGE FAMILY? B & B?

Almost 2500 sq. ft. on two levels. 4 bdrms., 3 bathrms., large family room, built 1977. Sundeck facing south, in quiet area of S.S.I. \$105,000 mls.



### OCEANVIEW WEST COAST CONTEMPORARY

2000 sq. ft. luxury living, architect designed, the best materials, outstanding finishing work. Located in beautiful Maracaibo Estates, where your investment provides you with year round moorage, swimming, tennis, parkland and miles of beach like this one. Ask for a personal tour. \$278,000 MLS.

DONNA REGEN, CGA  
537-2845

"EXPERIENCE MAKES THE DIFFERENCE"

**SMALL WORLD REAL ESTATE COMPANY INC.**

**SWEEPING VIEW IN PREFERRED AREA OF LARGE LOTS** — This 5 acre home site has it all. Driveway and cottage site prepared, drilled well. Build cottage now and admire the view while planning your future home. Sun, privacy and class for \$59,900.

**BUSINESS MINDED??** Work in pleasant surroundings, with year round clientele. Retail & small mfg. requires 2 people to operate. Steady growth. \$89,500 plus very active stock. Ask for details.

From the **SMALL WORLD NETWORK** — **SCOTSDALE, ARIZONA** — Gracious 3000 sq. ft. home, on 1 1/4 ac. with I/G heated diving pool, gazebo, mature landscaping, security system, many luxuries in quiet setting on 17th Fairway of Orange Tree Golf Resort. Walk to tennis/racquet club. Room for expansion. Motivated vendor asking US\$345,000.

**HERE'S THE PROPERTY** for a **VIABLE, PHASED COM'L, RECREATIONAL & RESIDENTIAL DEVELOPMENT** — 35 ac of south & west facing lakefront. Too many opportunities to list. Call for details.

**MAYNE ISLAND — WATERFRONT**  
Very pretty setting for your home or cottage on Campbell Bay. Lots of sun, good building sites, power and piped water. \$46,500.

**GALIANO ACREAGES**  
Georgia View — 9 plus ac. w/spectacular views. On paved road. Access to beach. \$58,000.

Thorburn Place — piped water, paved road.  
5 acres \$22,000.  
10 acres \$29,000.

Vendor anxious to sell, bring your offer.

For quality property in all price ranges

**SMALL WORLD REAL ESTATE CO. INC.**  
P.O. Box 1022, GANGES, B.C. V0S 1E0. (604) 537-9977  
JESSIE (PAT) JAMES (604) 537-5224



**GRACE POINT**

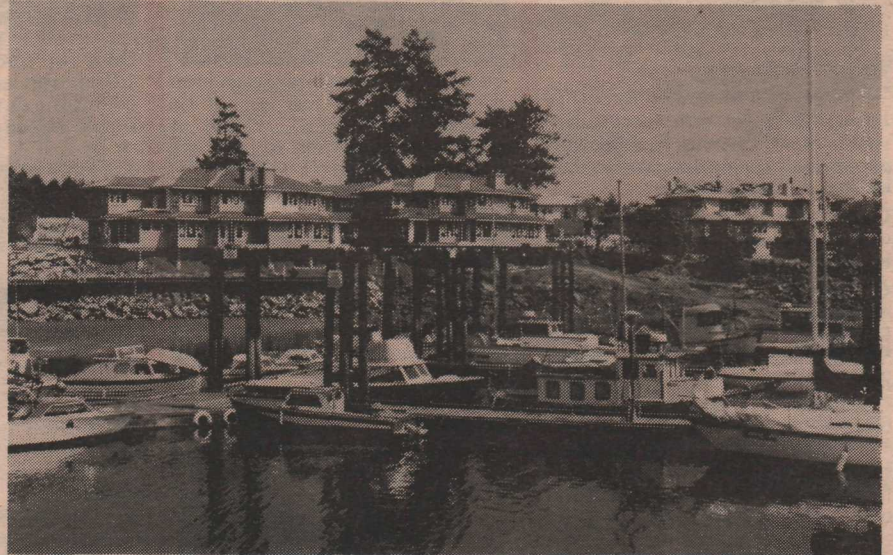

**SALT SPRING'S ONLY OCEANFRONT TOWNHOMES**

Enjoy the very best of the Gulf Islands: Superb waterfront location, private residents' moorage, spectacular harbour views, sunny decks just steps from the ocean. Twenty-one exclusive townhome residences now under construction for 1988 occupancy. Two bedrooms, dens, luxury features and exceptional design. Excellent choices still available from \$198,500.

**Century 21**  
ISLANDS REALTY LTD.

**CONTACT: TOM HOOVER**

BOX 454, GANGES, B.C. V0S 1E0  
(604) 537-9981

**OVER 66% SOLD**

-2



**BRINKWORTHY PLACE**

Have you seen what's happening at the **NEW Brinkworthy Place?**  
New homes keep arriving and more people are enjoying:

- \* their own custom designed home
- \* meeting new friends
- \* the terrific social centre facilities
- \* a convenient location
- \* more leisure time

Drive by and see the new display homes - open Tuesday and Saturday — 10 am. to 2 pm.

**CALL BECKY, BRIAN OR TOM FOR A PERSONAL TOUR**

1101  
GRACE POINT  
SQUARE  
P.O. Box 454  
Ganges, B.C.  
V0S 1E0

**537-9981**  
FAX #537-9551

**Century 21**  
ISLANDS REALTY LTD.  
WE SET THE STANDARD

THE LARGEST  
REAL ESTATE  
ORGANIZATION  
IN THE WORLD  
EACH OFFICE IS  
INDEPENDENTLY  
OWNED AND  
OPERATED  
\* and \* Members of  
Century 21 Real Estate Corporation  
**MLS**  
MULTIPLE LISTING SERVICE

**THETIS ISLAND**



**Where Eagles Soar and Otters Play...**

Enjoy your 156' of lowbank waterfront as you harvest clams and oysters. This one-of-a-kind cedar waterfront home sits on 1 1/2 sunbaked acres on Thetis Island. Open-plan living with lots of glass to take in panoramic view. Satellite dish, hot tub overlooking ocean. This SW facing beauty has seasonal moorage with year-round moorage nearby. Only 20 minutes to Vancouver Island by ferry! Values like this sell fast! **CALL TODAY!** \$170,000. Call 246-4842.

**QUESTIONS ABOUT REAL ESTATE?**

**ASK A PROFESSIONAL!**



ASK A MEMBER OF THE REAL ESTATE BOARD

**Recreation, Retirement & Investment Properties  
on Salt Spring & the beautiful Gulf Islands**

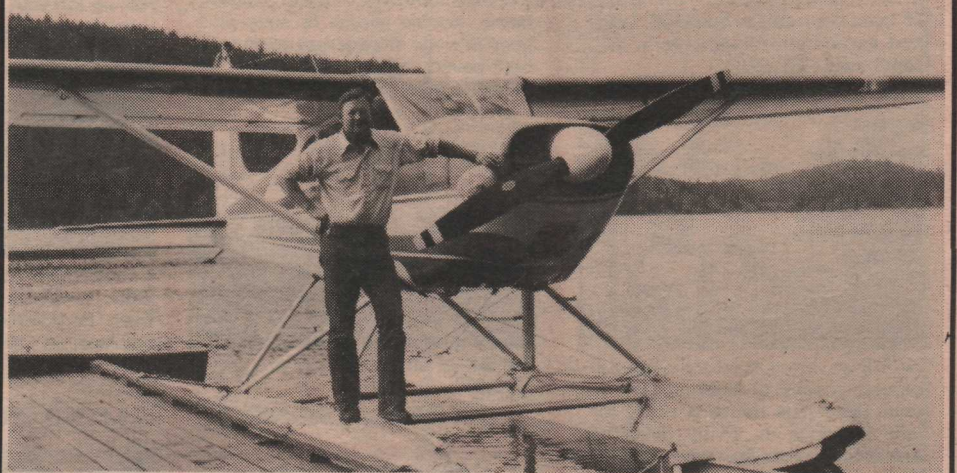

For personalized service contact

**ED DAVIS**

*Waterfront & Island specialist*

Res. 537-2626

Selling or buying I cover the islands.

17 years resident, realtor, commercial bush pilot,  
seasoned illustrative photographer.

1101  
GRACE POINT  
SQUARE  
P.O. Box 454  
Ganges, B.C.  
V0S 1E0

**537-9981**  
FAX #537-9551

**Century 21**  
ISLANDS REALTY LTD.  
WE SET THE STANDARD

THE LARGEST  
REAL ESTATE  
ORGANIZATION  
IN THE WORLD  
EACH OFFICE IS  
INDEPENDENTLY  
OWNED AND  
OPERATED  
\* and \* Members of  
Century 21 Real Estate Corporation  
**MLS**  
MULTIPLE LISTING SERVICE



# SALT SPRING REALTY LTD.

SERVING SALT SPRING ISLAND FOR 61 YEARS  
 149 Fulford-Ganges Rd., Box 69, Ganges, B. C. V0S 1E0  
 (formerly Salt Spring Lands Ltd.)

Phone 537-5515  
 Victoria Dir. Line 656-5554  
 Fax Number 537-9797

### A VIEW FROM THE TOP



Lovely hilltop lot with spectacular view of Stuart Channel. Piped water, phone, hydro and cablevision to the lot line. Asking \$59,000.

Close to the lake, lovely secluded lot with hydro, water, driveway already in. Asking \$45,000.

#### COMPARE THESE PRICES:

- \* \$35,500 - 4.97 acres, Richard Flack Rd., Lot 3
- \* \$35,500 - 4.97 acres, Richard Flack Rd., Lot 4
- \* \$22,000 - 1/2 acre building site, Head St., Walker Hook
- \* \$17,000 - 1/3 acre building site, Head St., Walker Hook.
- \* \$69,000 - 3.5 acre parcel with home, barn & workshop.

For more information, contact:  
**PHYLLIS FETHERSTONE**  
 537-2095

### REDUCTION!



Now only \$109,000! (Assessed at \$111,000) Mobrae. Lakeview. 3 BR. full basement, 3/4 ac. corner lot. All appliances included.

#### ST. MARY HIGHLANDS

Building lot. .56 ac. Southbank Drive. Easy to develop. Nice quiet area of good homes. \$24,500.

#### COTTAGE ON 1 1/2 ACRES

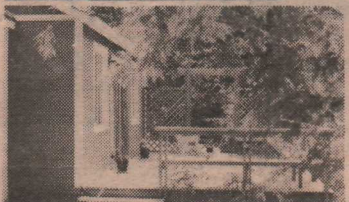

Ideal artist's studio. Quiet, sunny, north end location. Revenue \$300/mo. Asking only \$48,500 (excellent terms).

PLEASE CALL DICK TRORY  
 537-2236

### ONE ACRE VIEW PROPERTY

to build your dream home on. Level and excavated. All services in incl. septic field. \$39,500.

#### BRAND NEW HOME



on 1/2 ac. lot in quiet cul-de-sac. If natural shades of finishing are to your taste, this house is ready for you to move in. Many delightful extras incl. vacu-flo, auto door to double garage. Must be seen to be appreciated. \$145,000.

#### NOW UNDER CONSTRUCTION

Brand new house with lovely ocean view and 1200 sq. ft. on two floors. Still time to choose the colours. Without delay - phone today. \$145,000.

CALL MARION MARKS  
 537-2453

### \*\*\*\* VIEW, VIEW, VIEW \*\*\*\*



Of the VIEW properties presently on the market, this has got to be **AMONG THE BEST**. Priced at \$65,000 and **BEST OF ALL—2 TO CHOOSE FROM.**

#### WATERFRONT

12 acres, cabin, Sansum Narrows. price \$139,000.

3.68 acres, Southey Point, water, power, phone, driveway, well treed, southern warm sunny exposure, warm swimming, privacy. Price \$189,000.

5.29 acres, private cove, good exposure, fully serviced, subdivision potential. Price \$225,000.

#### SCOTT POINT WATERFRONT



Architect design home, moorage, Price \$249,000. Price has been reduced.

MEL TOPPING  
 537-2426

### HOUSES



Cottage & studio on level sunny .39 ac., power, water, cable, on a quiet road. \$69,500 MLS.



Country Comfort, 2 bdrm., quality home, double garage & suite plus shop & wood storage, set up on easy care paved parking area. 2.21 ac. of peace & quiet. \$132,000 MLS.



320 ac. of secluded view property. \$225,000.

JIM SPENCER 537-2154

#### ST. MARY'S HIGHLANDS FOR \$21,000?

That's right - plus a nice storage shed & driveway, piped water, cable & a sea glimpse thrown in.

#### POSSIBLE 4 LOT SUBDIVISION

20 acres within a mile of Ganges. Secluded & quiet. Very well priced at \$79,000.

DENNIS O'HARA  
 537-2491

### VIEW MINI-FARM



Large two storey family home on 3-1/3 ac. with landscaped yard, barn, outbuilding & fencing. Ample water supply. Priced at \$175,000.

#### WATERFRONT



168 ACRES on Sansum Narrows, with approx. 1/4 mile of waterfront. Property rises to an expansive seaweave view. Water access only. Subdividable, plus vendor financing. Offered at \$225,000.

CALL RUSS CROUSE 537-5203

### FULFORD ACREAGES

\* 19.75 acres - half pasture/half treed. Southfacing exposure, ocean views, convenient to ferry. \$99,000.

\* Over 5 acres spectacular ocean views, full day sun, driveway to building site, hydro to lot line. Total privacy & quiet near Ruckle Park. \$79,000.

\* 2 1/4 acres all pasture land, Artesian drilled well surrounded by farms. Beaver Point Road. Priced to sell - \$22,000.

\* 5 sunny acres, southwest facing, partially cleared & seeded. Building site developed across from riding ring. \$49,000.

STRICK AUST  
 537-5828

REVENUE PRODUCING - Vendor has purchased in another area & needs to sell 3 bdrm. home, studio, cabin, 1 - 4 plex on 5 acres of land. Producing \$1325/mo. Asking \$135,000.

SEAVIEW LOT - The Hundred Hills area, level & easy to build on. Asking \$55,000.

#### VIEWS, VIEWS, VIEWS, VIEWS



Ganges Harbour, Active Pass & Mt. Baker, newly decorated 3 Bdrm. split level, family room, oak floors & fireplace in living room, double carport, paved driveway. Asking \$127,500.

#### FULFORD CHALET



2 bdrm., 2 level home in village, open floor plan with vaulted ceilings. Close to everything. Asking \$84,900.

BOB TARA 653-4435

### A GOOD DEAL JUST GOT BETTER — PRICE REDUCED TO \$69,900



- \* Well laid out 3 bdrm.
- \* 1 level/large kitchen
- \* Fireplace/separate laundry
- \* Close to school, store & dock

### REDUCTION/REDUCTION/REDUCTION



- \* Three bdrms.
- \* Two baths
- \* 1.19 acres
- \* Fireplace/lots of cedar

**NORMAN ROTHWELL**  
 537-5103  
 Committed to Giving You the Best Service

### RETIRING? STARTING OUT?

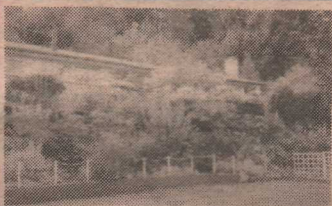

If you are in the above buyer category, don't miss this immaculate 1400 sq. ft. lakeview bungalow. Location perfect, workshop, lakeview, 2 BR., large family room. A must to view. Asking price \$105,000.

#### BEST BUY BUILDING LOTS (\$25,000 EACH)

Two lovely level 1/2 acre lots with seaweave glimpses. Easy to build on, well on one. Call today for further information.

#### LOOK AT THE FIGURES!!



Call Maggie today to see the investment opportunity on this strata-duplex. Asking price \$139,900.

MAGGIE SMITH

### AFFORDABLE STARTER



- \$79,500
- 3 BR. A-frame
- Excellent seaweaves
- Parklike 3/4 acre
- Workshop, etc.

### QUICK POSSESSION



- \$139,000
- Waterfront home
- Year round moorage
- 2200 sq. ft., 2 level
- In-law suite

#### RUSTIC CABIN

- \$45,000
- Near Walker Hook
- .50 acre, seasonal creek
- Liveable year round

FREE MARKET EVALUATION  
**PAUL GREENBAUM**  
 537-5064 (24 hrs.)

### NORTH END LOCATION



- \* within 5 min. walking distance of 5 accesses to the salt water
- \* private setting of 2.35 acres
- \* quality 3 bdrm. home & den
- \* serviced with domestic water & cable TV.
- \* Good value at \$169,500.

#### SOUTH-END BED & BREAKFAST



- \* Approx. 2885 sq. ft. living
- \* 5 acres, 5 bdrms.
- \* Sunny S.W. exposure
- \* POND & pastoral views
- LIST PRICE \$139,500.

GIL MOUAT 537-9272

Tell us what you want in island real estate!

- Waterfront  Homes  View Homes
- Farm/Ranch  Acreage  Building Lot
- Free Catalogue

Name \_\_\_\_\_

Address \_\_\_\_\_

Postal Code \_\_\_\_\_ Phone \_\_\_\_\_

Mail to NRS Salt Spring Realty Ltd.  
 P.O. Box 69, Ganges, B. C. V0S 1E0

NORTH AMERICA'S *Finest!* REAL ESTATE MARKETING SYSTEM.